

# TRAILER SPECIFICATION

## MobiLED SLM21e

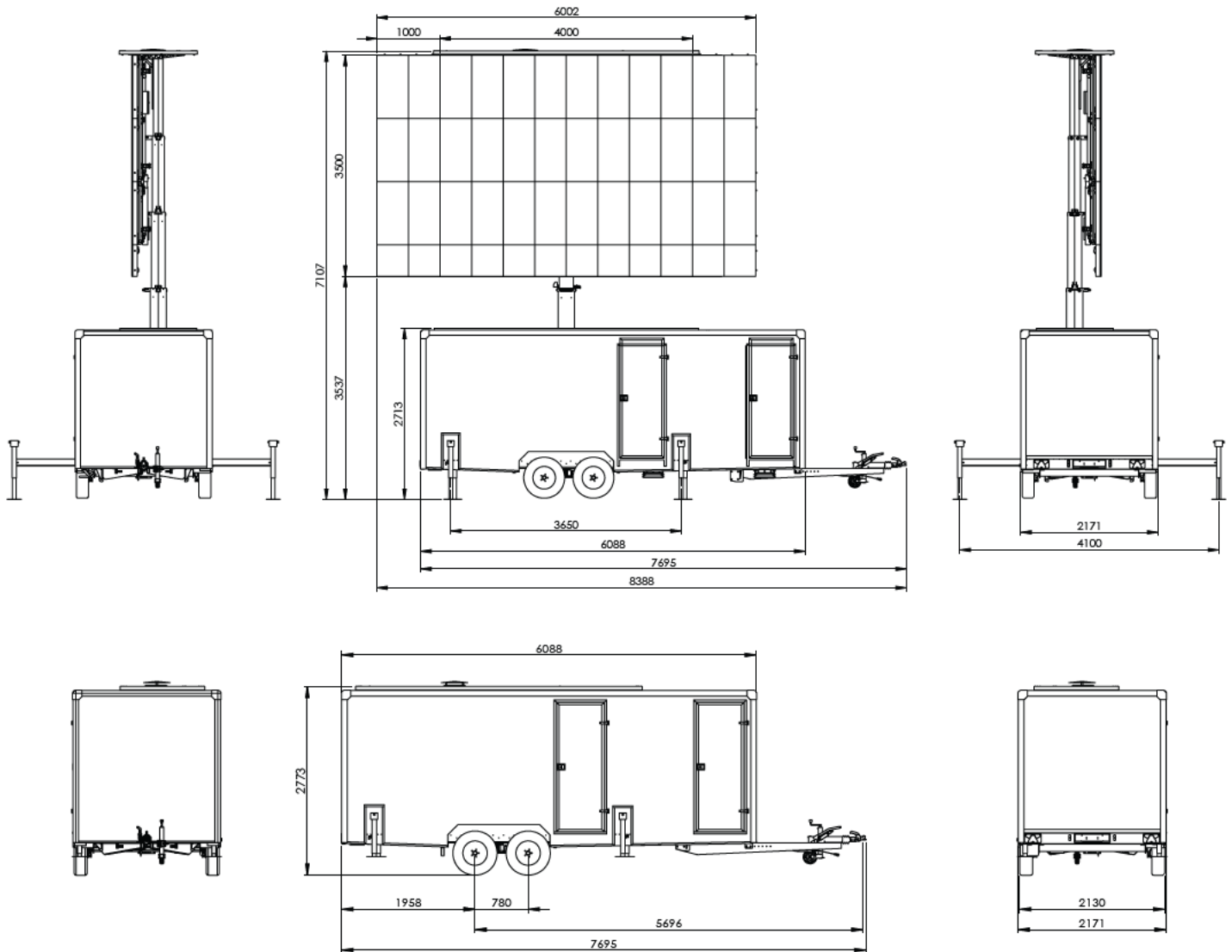

CarpeDiem  
evenement



### DIMENSIONS FOR TRANSPORT

Lenght with drawbar	7695 mm
Lenght without drawbar	6088 mm
Width	2170 mm
Height	2773 mm

### DIMENSIONS WITH UNFOLDED SCREEN

Width	4100 mm
Lenght	8388 mm
Height to top of the screen	7107 mm
Height to bottom of the screen	3537 mm

### WEIGHT

GVWR weight	3500 kg
Real weight with the screen	≈ 3300 kg
Real weight without the screen	≈ 2700 kg

### LED SCREEN DETAILS

Area	21 m <sup>2</sup>
Width	6 m
Height	3.5 m
Model	Unilumin URMIII03 P3.9 or your LED screen
Resolution P3.91	1536 x 896 px
Videoprocessor	Novastar VX6S



### HYDRAULIC SYSTEM

Motor power	1,5 kW (400V)
Flow rate	6 dm <sup>3</sup> /min
Nominal pressure	11 MPa
Oil type	HL46 or HL32 (for lower temperatures)
Oil quantity	≈ 46 dm <sup>3</sup>

### POWER

Power socket	400V 32A
Power generator	✗
Screen turned on Max. power consumption	≈ 14 kW
Screen turned on Avg. power consumption	≈ 4 kW
Screen mast Power consumption (lifting, rotation)	≈ 1,5 kW
Other equipment Power consumption (wind sensor, video processor etc.)	max. 0,5 kW

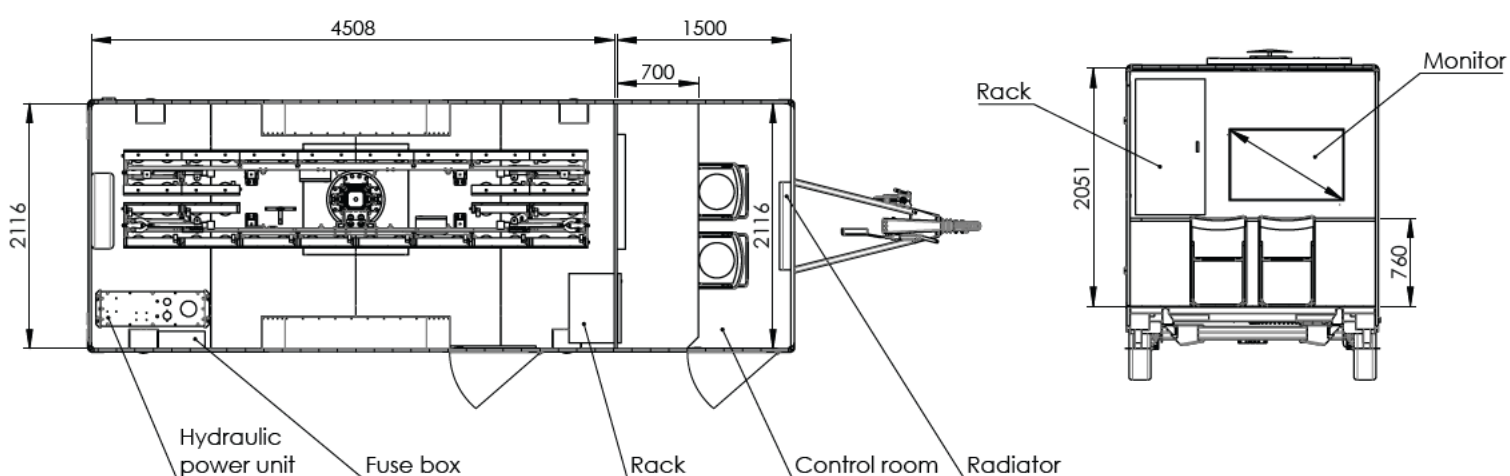

### CONSTRUCTION

Chassis	Galvanized, made according to DIN EN 13814 and DIN EN 13782
Axles and brakes	2x AL-KO
Mast	360° hydraulic rotated, galvanized and black powder coated
Mast control	remote controller, hydraulic levers and emergency hand pump
Walls	Sandwich material (25 mm)
Color	in standard - silver (RAL 9006) additional fee - any from RAL
Wind sensor	according to DIN EN 13814 (with alarm)

### OTHER DETAILS

Wind rating	20 m/s (72 km/h) 15 m/s for TÜV norms
IP rating	IP65 (fully waterproof)
Road approval	EU road approval
Axles	dual axle
Mast control	remote controller, hydraulic levers and emergency hand pump
Warranty	3 years