

ROBE

Painte® Spot

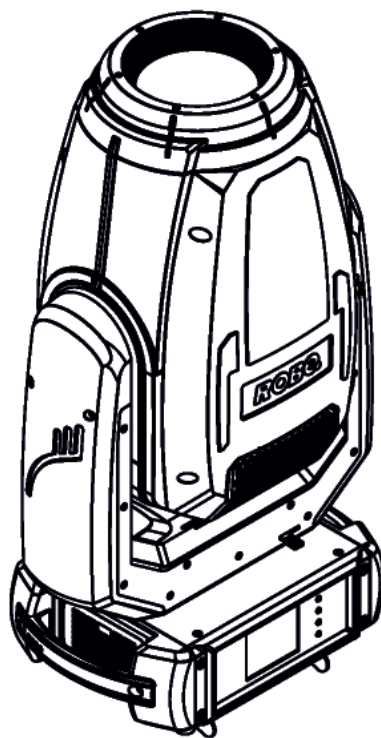

ROBE
Innovative
Technology

QR code for user manual



USER MANUAL

ROBE® lighting s.r.o. • Czech Republic • www.robe.cz

Version 1.3

Painte Spot

Table of contents

| | |
|--|-----------|
| 1. Safety instructions | 3 |
| 2. Fixture exterior view | 5 |
| 3. Installation | 6 |
| 3.1 Connection to the mains | 6 |
| 3.2 Rigging the fixture | 7 |
| 3.3 DMX-512 connection..... | 9 |
| 3.4 Ethernet connection | 10 |
| 3.5. Wireless DMX operation | 11 |
| 3.6. Replacing rotating gobos | 12 |
| 3.7 Replacing the frost | 12 |
| 4. Remotely controllable functions | 14 |
| 5. Control menu map | 15 |
| 6. Control menu | 19 |
| 6.1 Tab "Address" | 20 |
| 6.2 Tab "Information" | 21 |
| 6.3 Tab "Personality" | 24 |
| 6.4 Tab "Manual Control"..... | 26 |
| 6.5 Tab "Stand-alone" | 26 |
| 6.6 Tab "Service" | 27 |
| 7. RDM | 30 |
| 8. Error and information messages | 31 |
| 9. Robe Ethernet Access Portal (REAP) | 33 |
| 10. Technical Specifications | 34 |
| 11. Maintenance and cleaning | 37 |
| 11.1 Replacing the fuse..... | 38 |
| 11.2 Checking plastic parts of the fixture..... | 38 |
| 11.3 Disposing of the product..... | 38 |
| 11. ChangeLog | 39 |
| 12. Appendix | 40 |
| 12.1 Changing the LED light source | 40 |
| 12.2. Obtaining information about the LED light source by mobile phone | 42 |

**FOR YOUR OWN SAFETY, PLEASE READ THIS USER MANUAL CAREFULLY
BEFORE POWERING OR INSTALLING YOUR ROBIN Painte Spot !**

Save it for future reference.

This device has left our premises in absolutely perfect condition. In order to maintain this condition and to ensure a safe operation, it is absolutely necessary for the user to follow the safety instructions and warning notes written in this manual.

The manufacturer will not accept liability for any resulting damages caused by the non-observance of this manual or any unauthorized modification to the device.

Please consider that damages caused by manual modifications to the device are not subject to warranty.

The Robin Painte Spot was designed for indoor use and it is intended for professional application only. It is not for household use.

1. Safety instructions

DANGEROUS VOLTAGE CONSTITUTING A RISK OF ELECTRIC SHOCK IS PRESENT WITHIN THIS UNIT!

Make sure that the available voltage is not higher than stated on the rear panel of the fixture. This fixture should be operated only from the type of power source indicated on the marking label. If you are not sure of the type of power supplied, consult your authorized distributor or local power company.

WARNING! This unit does not contain an ON/OFF switch. Always disconnect power input cable to completely remove power from unit when not in use or before cleaning or servicing the unit.

Make sure that the power cord is never crimped or damaged by sharp edges. Check the fixture and the power cord from time to time.

Refer servicing to qualified service personnel.

This fixture falls under protection class I. Therefore this fixture has to be connected to a mains socket outlet with a protective earthing connection.

Do not connect this fixture to a dimmer pack.

LED light emission. Risk of eye injury. Do not look into the beam at short distance of the of the product. Do not view the light output with optical instruments or any device that may concentrate the beam.

If the fixture has been exposed to drastic temperature fluctuation (e.g. after transportation), do not switch it on immediately. The arising condensation water might damage your device. Leave the device switched off until it has reached room temperature.

Avoid brute force when installing or operating the fixture.

This fixture was designed for indoor use only, do not expose this unit to rain or use near water.

When choosing the installation spot, please make sure that the fixture is not exposed to extreme heat, moisture or dust.

Air vents and slots in the fixture's head and base are provided for ventilation, to ensure reliable operation of the device and to protect it from overheating.

Do not block the front lens with any object when the fixture is under operation.

CAUTION! Risk group 2, RG-2



The cooling openings should never be covered with cloth or other materials, and never must be blocked.

This fixture should not be placed in a built-in installation unless proper ventilation is provided.

Only operate the fixture after having checked that the housing is firmly closed and all screws are tightly fastened.

Always use a secondary safety wire when rigging this fixture.

Make sure that the area below the installation place is blocked when rigging, de-rigging or servicing the fixture.

The fixture becomes very hot during operation. Allow the fixture to cool approximately 20 minutes prior to manipulate with it.

Operate the fixture only after having familiarized with its functions. Do not permit operation by persons not qualified for operating the fixture. Most damages are the result of unprofessional operation!

Please use the original packaging if the fixture is to be transported.

Please consider that unauthorized modifications on the fixture are forbidden due to safety reasons!

If this device will be operated in any way different to the one described in this manual, the product may suffer damages and the guarantee becomes void. Furthermore, any other operation may lead to dangers like short-circuit, burns, electric shock, crash etc.

To avoid damage of the internal optical system of the fixture, never let the sunlight or other fixture lights directly to the front lens , even when the fixture is not working !

The product (covers and cables) must not be exposed to a high frequency electromagnetic field higher than 3V/m.

Immunity of the equipment is designed according to the standard EN 55035 Electromagnetic compatibility of multimedia equipment - Immunity requirements.

Emission of the equipment complies with the standard EN55032 Electromagnetic compatibility of multimedia equipment – Emission Requirements according to class B.

Contains FCC ID: 2A6PL-DMXRDMRW001*

Contains IC: 29573-DMXRDMRW001*

* Wireless DMX version of the fixture only.

This device complies with part 15 of the FCC Rules. Operation is subject to the following two conditions: (1) This device may not cause harmful interference, and (2) this device must accept any interference received, including interference that may cause undesired operation.

Changes or modifications not expressly approved by the party responsible for compliance could void the user's authority to operate the equipment.

The [Device] wireless operation is safe and complies to RF Exposure requirements

This equipment has been tested and found to comply with the limits for a Class B digital device, pursuant to part 15 of the FCC Rules. These limits are designed to provide reasonable protection against harmful interference in a residential installation. This equipment generates, uses and can radiate radio frequency energy and, if not installed and used in accordance with the instructions, may cause harmful interference to radio communications. However, there is no guarantee that interference will not occur in a particular installation. If this equipment does cause harmful interference to radio or television reception, which can be determined by turning the equipment off and on, the user is encouraged to try to correct the interference by one or more of the following measures:

- Reorient or relocate the receiving antenna.
- Increase the separation between the equipment and receiver.
- Connect the equipment into an outlet on a circuit different from that to which the receiver is connected.
- Consult the dealer or an experienced radio/TV technician for help.

2. Fixture exterior view

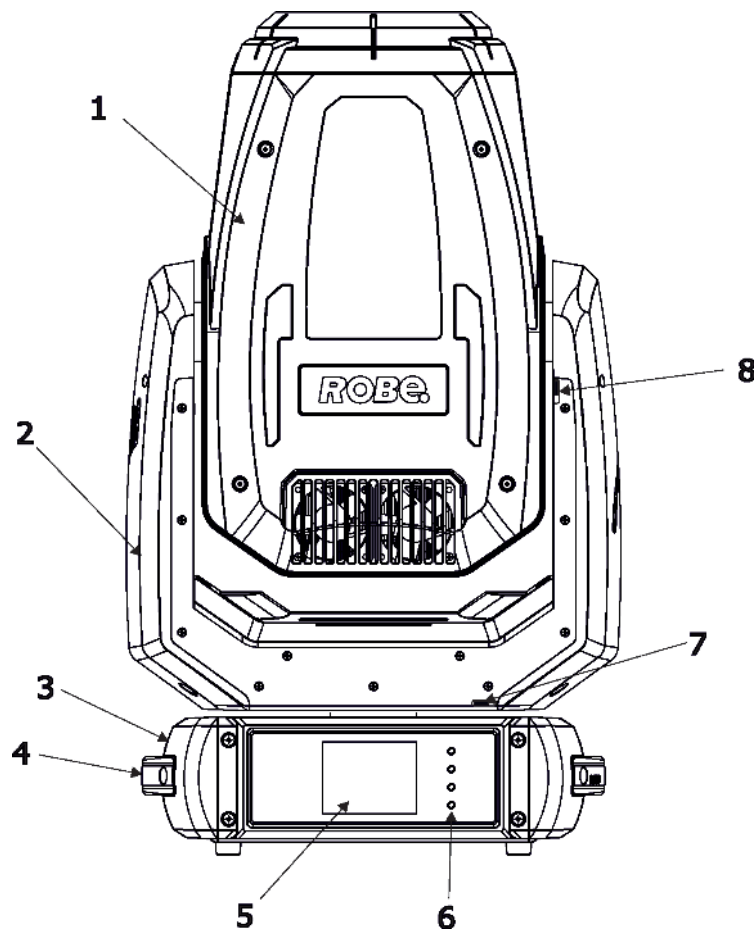

Rear panel of the base

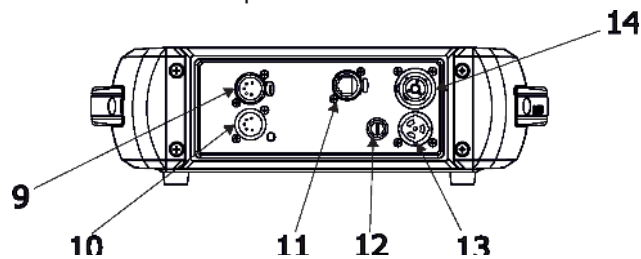

Rear panel of the base - EP version

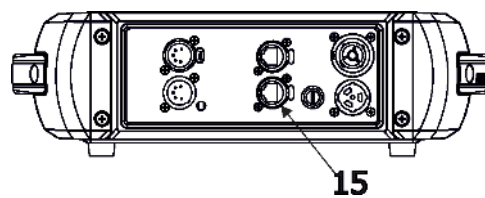

- | | |
|---------------------|---|
| 1- Moving head | 8 - Tilt lock |
| 2 - Yoke | 9 - DMX OUT (5-pin XLR) |
| 3 - Base | 10 - DMX IN (5-pin XLR) |
| 4 - Handle | 11 - Fuse holder |
| 5 - Touch screen | 12 - Mains IN (Neutrik powerCON TRUE1) |
| 6 - Control buttons | 13 - Mains OUT (Neutrik powerCON TRUE1) |
| 7 - Pan lock | 14 - Ethernet OUT (RJ 45) - EP version only |
| | 15 - Ethernet IN (RJ 45) |

The head has to be locked for transportation - the pan lock latch (7) and the tilt lock latch (8) have to be in the locked positions. To unlock the head, move these latches to unlock positions before operating the fixture.

3. Installation



Fixtures must be installed by a qualified electrician in accordance with all national and local electrical and construction codes and regulations.

3.1 Connection to the mains

For protection from electric shock, the fixture must be earthed!

The Robin Painte Spot is equipped with auto-switching power supply that automatically adjusts to any 50-60Hz AC power source from 100-240 Volts.

If you need to install a power plug on the power cable to allow connection to power outlets, install a ground-ing-type (earthed) plug following the plug manufacturer's instructions. If you have any doubts about proper installation, consult a qualified electrician.

| Core (EU) | Core (US) | Connection | Plug Terminal Marking |
|--------------|-----------|------------|-----------------------|
| Brown | Black | Live | L |
| Light blue | White | Neutral | N |
| Yellow/Green | Green | Earth | |

This device falls under class one and must be earthed (grounded)!

Design of the ROBIN Painte Spot allows you to connect several fixtures to AC mains power in one interconnected chain using power input and throughput connectors. Needed daisy chain cords are stated in the chapter "Technical specifications "

Maximum number of linked fixtures depends on input voltage:

CE:

7 fixtures at power supply= 230V

6 fixtures at power supply= 208V

4 fixtures at power supply= 120V

US:

5 fixtures at power supply= 230V

5 fixtures at power supply= 208V

3 fixtures at power supply= 120V

Real numbers of fixtures may differ from values stated above as you have to take into account the length of supply cables, circuit breaker etc. at projecting of the fixtures installation Do not overload the supply line and connecting leads.

!

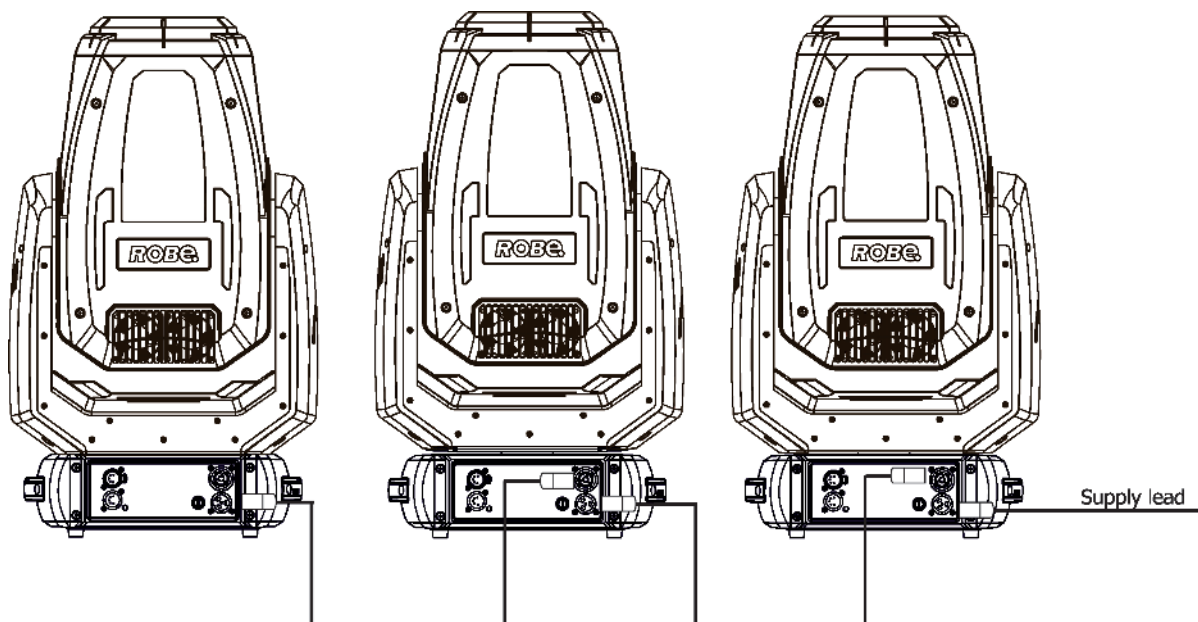

3.2 Rigging the fixture

A structure intended for installation of the fixture (s) must safely hold weight of the fixture(s) placed on it. The structure has to be certificated to the purpose.

The fixture (fixtures) must be installed in accordance with national and local electrical and construction codes and regulations.

For overhead installation, the fixture must be always secured with a safety wire that can bear at least 10 times the weight of the fixture.

When rigging, de-rigging or servicing the fixture staying in the area below the installation place, on bridges, under high working places and other endangered areas is forbidden.

The operator has to make sure that safety-relating and machine-technical installations are approved by a skilled person once a year.

The fixture should be installed outside areas where persons may walk by or be seated.

IMPORTANT! OVERHEAD RIGGING REQUIRES EXTENSIVE EXPERIENCE, including (but not limited to) calculating working load limits, installation material being used, and periodic safety inspection of all installation materials and the fixture. If you lack these qualifications, do not attempt the installation yourself, but instead use a professional structural rigger. Improper installation can result in bodily injury or damage to property. The fixture has to be installed out of the reach of people.

The fixture must never be fixed swinging freely in the room.

Caution: Fixture may cause severe injuries when crashing down! If you have doubts concerning the safety of a possible installation, do not install the moving head!

Before rigging make sure that the installation area can hold a minimum point load of 10 times the fixture's weight.

When installing the device, make sure there is no highly inflammable material (decoration articles, etc.) in a distance of min. 0.4 m.

CAUTION!
Use an appropriate clamps to rig the fixture on the truss.
Make sure that the device is fixed properly! Ensure that the structure (truss) to which you are attaching the fixture is secure.

The fixture can be placed directly on the stage floor or rigged in any orientation on a truss without altering its operation characteristics .

For securing the fixture to the truss, install a safety wire which can hold at least 10 times the weight of the fixture. Use only the safety wire with a snap hook with screw lock gate.

Truss installation

1. Bolt each clamp (1) to the omega holder (2) with M12 bolt and lock nut through the hole in the holder.
2. Fasten the omega holders to the bottom of the base by inserting both quick-lock fasteners (1) into the holes of the base and tighten fully clockwise.
3. Clamp the fixture on a truss (3) and tighten the rigging clamps.
4. Pull a safety wire (5) through the carrying handle and the truss (3) as shown on the picture above in a suitable position so that the maximum fall of the fixture will be 20 cm. Fasten a snap hook in the attachment point (6). Use only the safety wire with snap hooks with screw lock gates.

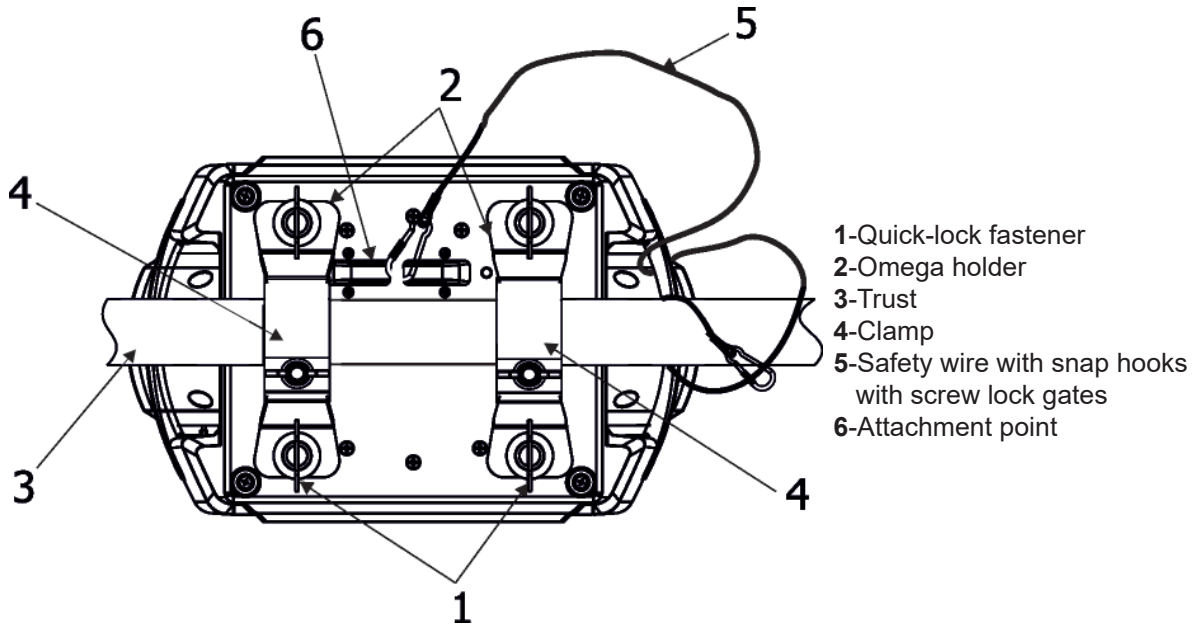

When installing fixtures side-by-side, avoid illuminating one fixture with another!

3.3 DMX-512 connection

The fixture is equipped with 5-pin XLR sockets for DMX input and output. Only use a shielded twisted-pair cable designed for RS-485 and 5-pin XLR-plugs and connectors in order to connect the controller with the fixture or one fixture with another.

DMX output

XLR socket (female)



- 1 - Shield
- 2 - Signal (-)
- 3 - Signal (+)
- 4 - Not connected
- 5 - Not connected

DMX input

XLR socket (male)



- 1 - Shield
- 2 - Signal (-)
- 3 - Signal (+)
- 4 - Not connected
- 5 - Not connected

If you are using the standard DMX controller, you can connect the DMX output of the controller directly with the DMX input of the first fixture in the DMX chain. If you wish to connect DMX controllers with other XLR output, you need to use adaptor cables.

Building a serial DMX-chain.

Connect the DMX output of the first fixture in the DMX chain with the DMX input of the next fixture. Always connect one output with the input of the next fixture until all fixtures are connected. Up to 32 fixtures can be interconnected.

Caution: At the last fixture, the DMX cable has to be terminated with a terminator. Solder a 120 Ω resistor between Signal (-) and Signal (+) into a (5-pin) XLR plug and plug it in the DMX output of the last fixture

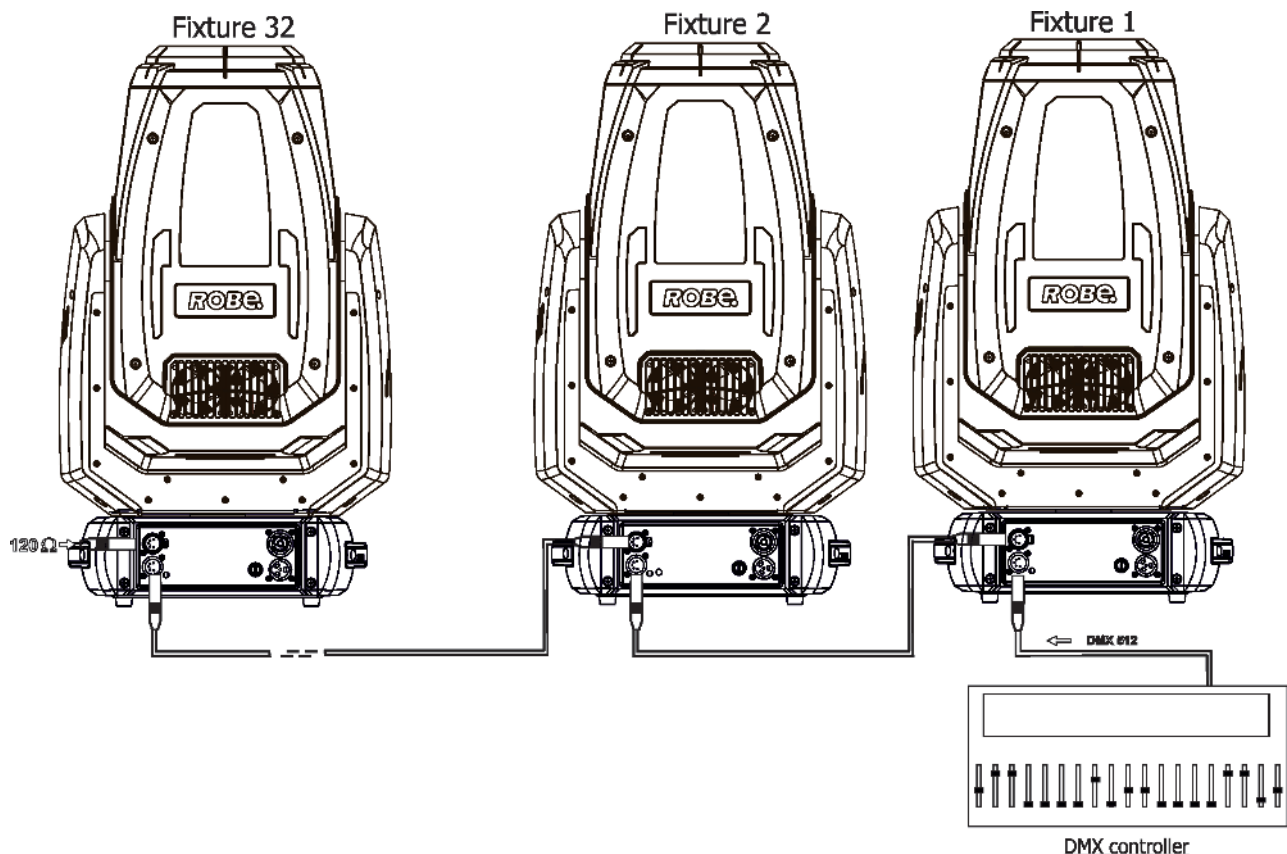

3.4 Ethernet connection

The fixtures on a data link are connected to the Ethernet with appropriate communication protocol (e.g. Art-Net). The control software running on your PC (or light console) has to support this communication protocol. Art-Net communication protocol is a 10 Base T Ethernet protocol based on the TCP/IP. Its purpose is to allow transfer of large amounts of DMX 512 data over a wide area using standard network technology.

The IP address is the Internet protocol address. The IP uniquely identifies any node (fixture) on a network.

The Universe is a single DMX 512 frame of 512 channels.

The Painte Spot is equipped with 8-pin RJ-45 sockets for Ethernet connection. Use a network cable category 5 (with four "twisted" wire pairs) and standard RJ-45 plugs in order to connect the fixture to the network.

RJ-45 socket (front view):

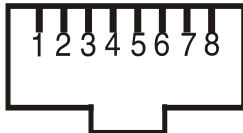

- 1- TD+
- 2- TD-
- 3- RX+
- 4- Not connected

RJ-45 plug (front view):

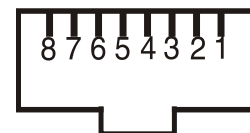

- 5- Not connected
- 6- RX-
- 7- Not connected
- 8- Not connected

Patch cables that connect fixtures to the hubs or LAN sockets are wired 1:1, that is, pins with the same numbers are connected together:

- 1-1 2-2 3-3 4-4 5-5 6-6 7-7 8-8

If only the fixture and the computer are to be interconnected, no hubs or other active components are needed. A cross-cable has to be used:

- 1-3 2-6 3-1 4-8 5-7 6-2 7-5 8-4

Connect the Ethernet inputs of all fixtures to the Ethernet network. Set their IP addresses and Net Masks. Correct communication protocol (e.g. "ArtNet") has to be selected from the menu "Ethernet Mode" in the fixtures (Addressing-->Ethernet -->Ethernet Mode). Set Universe(s) according to communication protocol.

Example of connection (EP version):

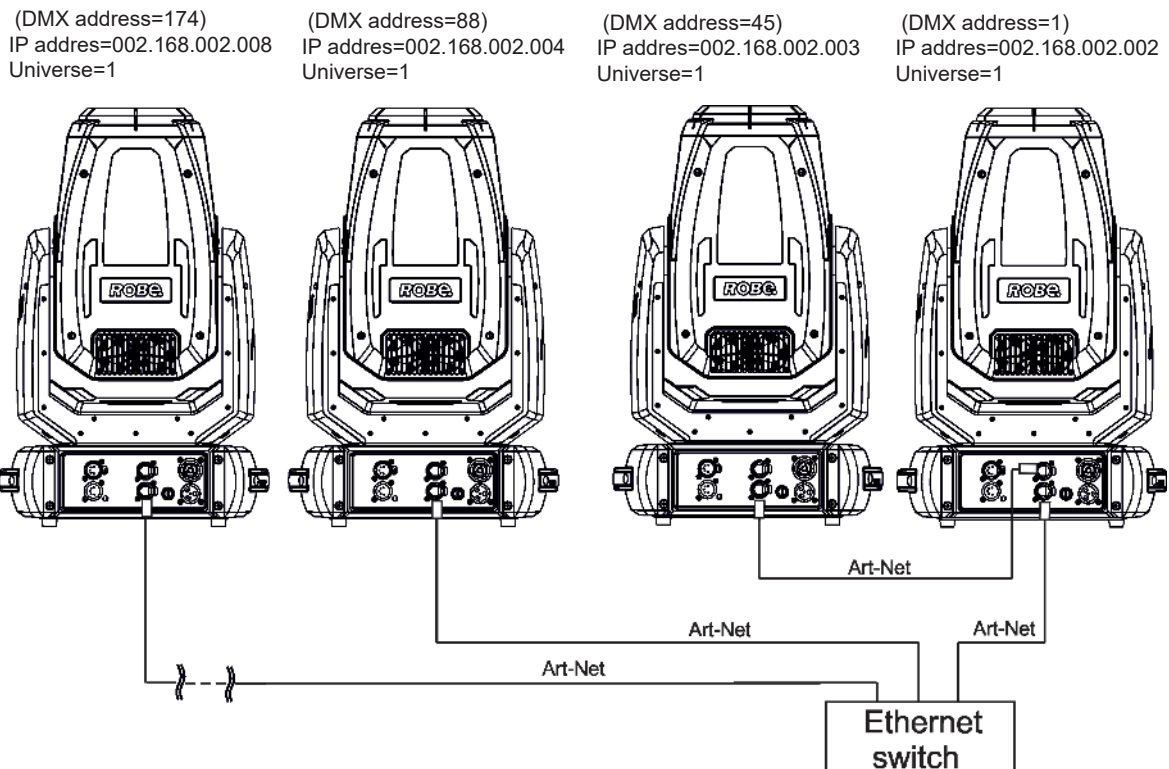

An advised PC setting: IP address: 002.xxx.xxx.xxx (Different from fixtures IP addresses)
NET mask: 255.0.0.0

The EP version of the fixture is equipped with Ethernet Pass Through Switch which sustains Ethernet integrity, when the fixture has no power, it automatically maintains network connectivity.

If you use the Ethernet IN-OUT way for the Ethernet connection, max. 8 fixtures can be connected in the IN-OUT line.

3.5. Wireless DMX operation

The wireless DMX version of the fixture is equipped with the wireless DMX/RDM module which has full support for wireless communication protocols at entertainment market. The module is based on well known Lumen-Radio RF technology, with implemented wire interface for connection with Robe products. RF output for MCX interface antenna as standard output.

The item " Wireless " from the menu "DMX Input" allows you to activate receiving of wireless DMX (Personality--> DMX Input -->Wireless.). First two options from the "DMX Input" menu are stated in DMX chart as well (channel Power/Special functions , range of 16-19 DMX). If DMX input option is changed by DMX command, the change is permanently written into fixture's memory.

DMX range of 16-19 switching fixture to the wired/wireless operation is active only during first 10 seconds after switching the fixture on.

After switching the fixture on, the fixture checks both modes of receiving DMX in the following order:

1. For the first five seconds, the fixture receives DMX signal from the wired input. If the Power/Special functions channel is set at some DMX input option, the fixture will receive DMX value according to this option. If DMX input option is set to the wired input , this option is saved and checking procedure is finished. If DMX input option is not set, the fixture continues next 5 seconds in scanning wireless DMX signal-see point 2.

2. For the next 5 seconds the fixture receives wireless DMX signal and again detects if the Power/Special functions channel is set at some DMX input option, if not, the fixture will take option which is set in the fixture menu "DMX Input".

To link the fixture with DMX transmitter.

The fixture can be only linked with the transmitter by running the link procedure at DMX transmitter .

After linking, the level of DMX signal (0-100 %) is displayed in the menu item "Wireless State" (Information -->Wireless State).

To unlink the fixture from DMX transmitter.

The fixture can be unlinked from transmitter via the menu item " Unlink Wireless Adapter" (Information--> Wireless State --> Unlink Wireless Adapter).

Example of connection.

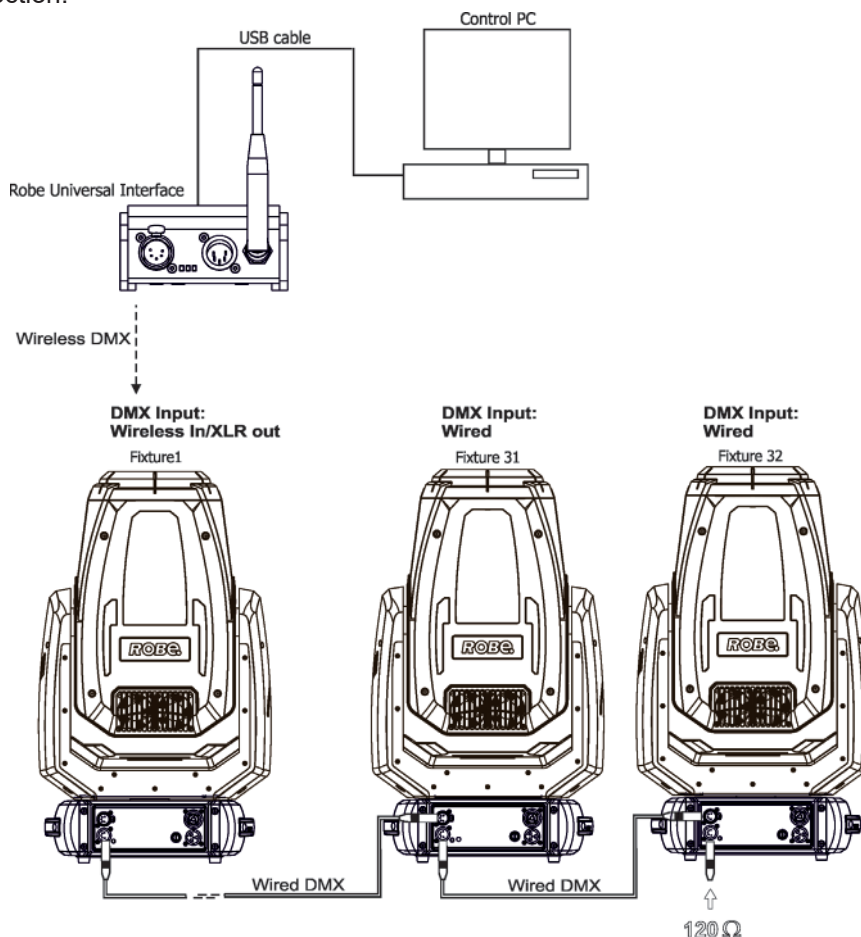

3.6. Replacing rotating gobos

Disconnect the fixture from mains before gobo replacing.

1. Disconnect the fixture from mains and allow it to cool.
2. Remove the plastic cover of the head by loosening the 4 quarter-turn fasteners on the cover.
3. Gently pull up the gobo holder from the rotation gobo wheel.
4. Carefully remove the spring gobo-lock and gobo from the gobo holder. Do not touch the surface of the pattern of the glass gobo - use a suitable glove. Be careful! Glass gobo!
5. Insert the new gobo (glazy side towards the LED source). Insert the spring-gobo lock to secure it in the gobo holder.
6. Insert the gobo holder back into rotating gobo wheel.
7. Replace the head cover before applying power.

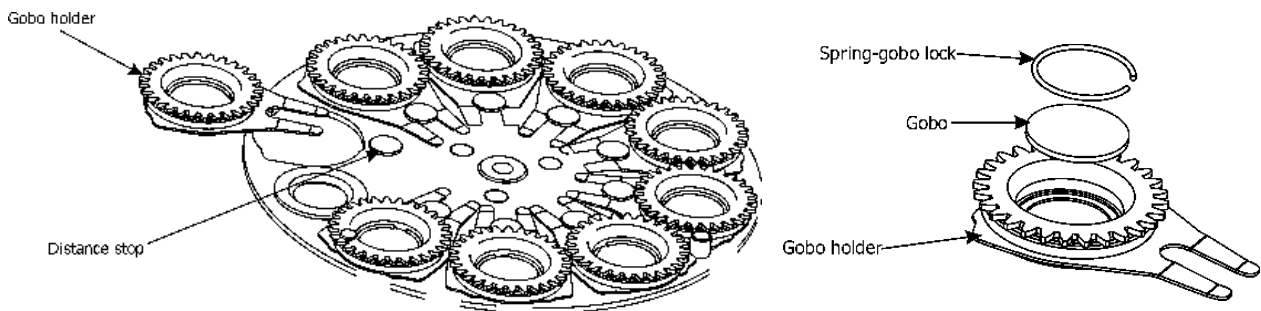

3.7 Replacing the frost

Unplug the fixture from mains before replacing the frost!

To replace the frost.

1. Disconnect the fixture from mains and allow it to cool for 10 minutes.
2. Remove plastic cover of the head by loosening the 4 quarter-turn fasteners on the cover to get access to the 5° frost.
3. The holder (2) of the frost foil is fastened to the frost holder (3) by means of the four magnets (4). Grip the holder (2) and carefully tilt it out to break a force of magnets (4) on the frost holder (3).
4. Place a new frost module into the frost holder (3). Check, that both slots (6) snapped correctly into two protrusions (5) in the holder (3).
5. Place the plastic cover back on the fixture before applying power.

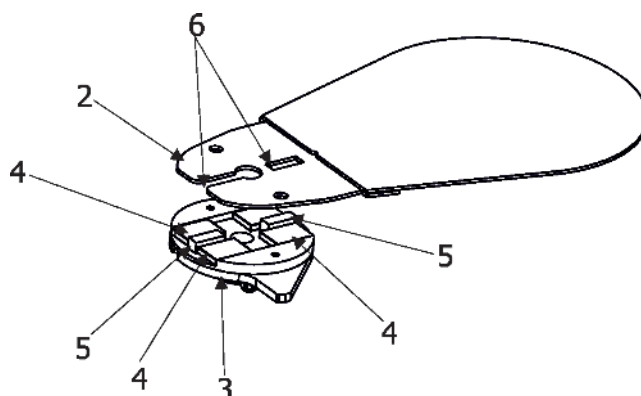

Note: Next replaceable frost module with 1°frost is placed in the fixture head:

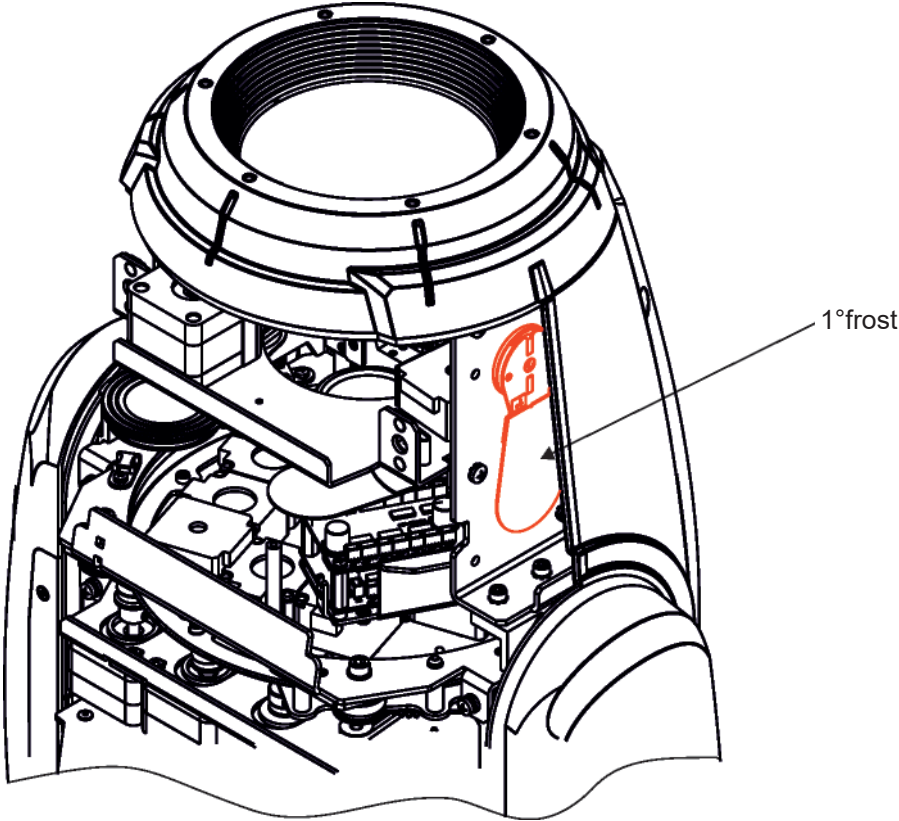

4. Remotely controllable functions

Colour wheel

The colour wheel with 9 dichroic filters rotates in both directions with variable speed which creates wide spectrum of graphic effects.

CMY colour mixing system

The CMY color mixing system is based on graduated cyan, magenta, and yellow colour filters. A continuous range of colors may be achieved by varying the amount of each filter from 0 to 100%.

Rotating gobo wheel

The rotating gobo wheel includes 8 glass gobos rotating in both directions, indexable, replaceable "SLOT&LOCK" system.

Static gobo wheel

The static gobo wheel includes 9 metal gobos. Gobo positioning and continual gobo positioning is available as well as a gobo-shake function.

Prism

The 8-facet radial prism rotates in both directions at different speeds.

Frost filter

Installed 5° frost filter provides variable frost for fine frosting and replaceable 1° frost filter is placed on the side in the fixture head.

Focus/Zoom

Motorized focus allows you to focus beam from approx. 2 meters to infinity. Zoom range 8° - 48°.

Dimmer/Shutter unit

Smooth 0 - 100 % dimming is provided by the electronic control unit. This unit is also used for strobe effects with variable speed.

Pan/Tilt

Pan/tilt movement range: 540°/270°. Built-in electronic motion stabilizer (EMS) which ensures precise position of the fixture's head during its movement and reduces its swinging when the truss shakes.

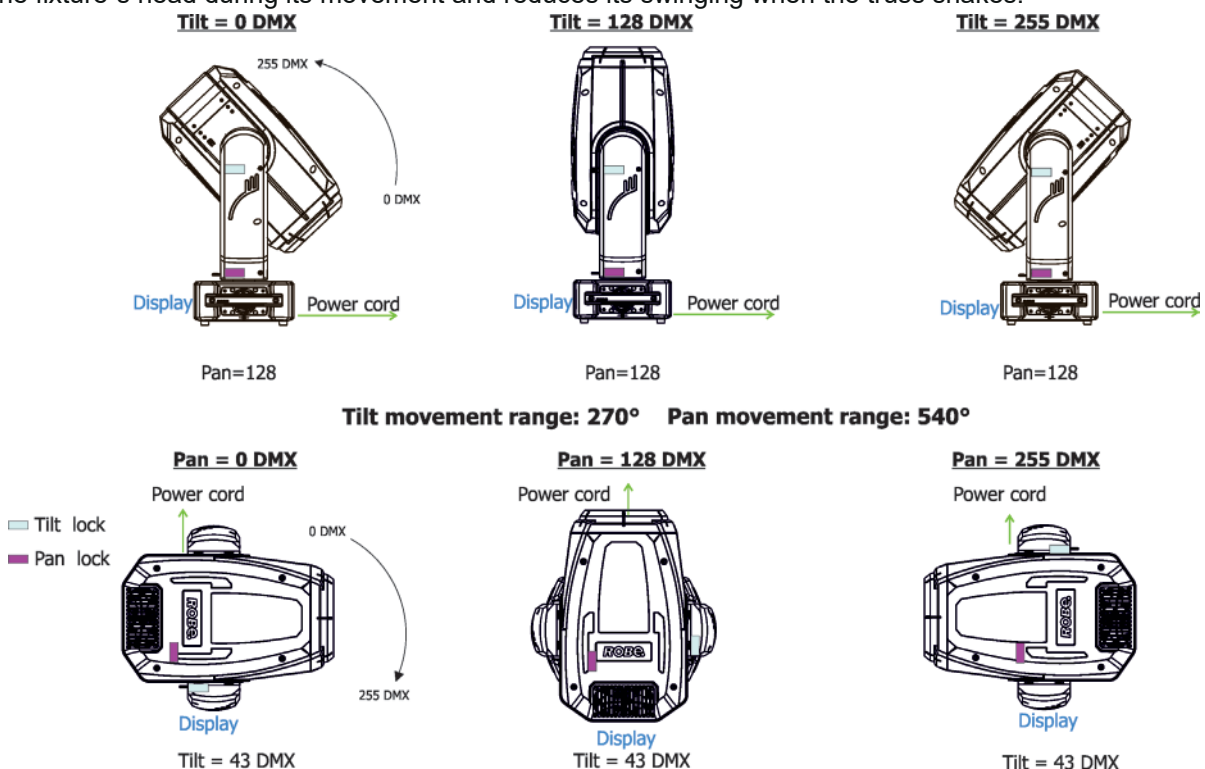



5. Control menu map

Default settings=Bold print

| Tab | Level 1 | Level 2 | Level 3 | Level 4 | Level 5 | Level 6 |
|---|----------------------|-------------------------|---------------------|--------------------|-------------|---------|
| Addressing | Settings | DMX Address | 001-512 | | | |
|  | | DMX Presets | Mode 1 | | | |
| | | | Mode 2 | | | |
| | | Ethernet Settings | Ethernet Mode | Disable | | |
| | | | | ArtNet | | |
| | | | | gMA1 | | |
| | | | | gMA2 | | |
| | | | | sACN | | |
| | | | Ethernet To DMX | Off , On | | |
| | | | IP Address/Net Mask | Default IP Address | | |
| | | | | Custom IP Address | | |
| | | | | Net Mask | | |
| | | | ArtNet Universe | 0-255 | | |
| | | | MANet settings | MANet/II Universe | 01-256 | |
| | | | | MANet Session ID | 01-32 | |
| | | | sACN Settings | sACN Universe | 00001-32000 | |
| | | | Ethernet as Backup | Disable | | |
| | | | | Enable | | |
| Information | Fixture Times | Power On Time | Total Hours | | | |
|  | | | Resetable Hours | | | |
| | | Air Filters | Elapsed Time | | | |
| | | | Alert Period | 10-300 | | |
| | Fixture Temperatures | LEDs Temperatures | Current | | | |
| | | | Maximum NonRes.. | | | |
| | | | Maximum Res.. | | | |
| | | Driver Temperature | Current | | | |
| | | | Maximum NonRes.. | | | |
| | | | Maximum Res.. | | | |
| | | Base Temperature | Current | | | |
| | | | Maximum NonRes. | | | |
| | | | Maximum Res. | | | |
| | DMX Values | Pan | | | | |
| | | : | | | | |
| | | Dimmer Fine | | | | |
| | Wireless State | Signal Quality | | | | |
| | | Unlink Wireless Adapter | | | | |
| | Power Channel state | | | | | |
| | Software Version | Display System | | | | |
| | | Module M | | | | |
| | | Module L | | | | |
| | | Module O | | | | |
| | | Module G | | | | |
| | | Module C | | | | |
| | | Module I | | | | |
| | Product IDs | Mac Address | | | | |
| | | RDM UID | | | | |
| | | RDM Label | | | | |

| Tab | Level 1 | Level 2 | Level 3 | Level 4 | Level 5 | Level 6 |
|---|------------------------|-------------------------|---------------------|----------------|---------|---------|
| | LED Module info | First Module Assembly | | | | |
| | | Actual Module Info | | | | |
| | | Assembly History | | | | |
| | | Intensity History | | | | |
| | LED Modules History | | | | | |
| | View Logs | Fixture Errors | | | | |
| | | Fixture States | Power On | | | |
| | | | Power Off | | | |
| | | Fixture Position | | | | |
| | | Fixture Temperatures | LEDs Temperature | | | |
| | | | Driver Temperatures | | | |
| | | | Base Temperatures | | | |
| | | | | | | |
| Personality | User Mode | User A Settings | | | | |
|  | | User B Settings | | | | |
| | DMX Presets | Mode 1 | | | | |
| | | Mode 2 | | | | |
| | DMX Input | Wired | | | | |
| | | Wireless | | | | |
| | | Wireless In/XLR Out | | | | |
| | Pan/Tilt Settings | Pan Reverse | Off, On | | | |
| | | Tilt Reverse | Off, On | | | |
| | | Pan/Tilt Feedback | Off, On | | | |
| | | Pan/Tilt mode | Time | | | |
| | | | Speed | | | |
| | Pan/Tilt Reset | With P/T | | | | |
| | | Without P/T | | | | |
| | | Tilt, then Pan | | | | |
| | | Pan, then Tilt | | | | |
| | Pan/Tilt EMS | Off, On | | | | |
| | Microphone Sensitivity | 1-10-20 | | | | |
| | Blackout Settings | Blackout During M.C. | Off, On | | | |
| | | Blackout while: | Pan/Tilt moving | Off, On | | |
| | | | Colour Wheel Moving | Off, On | | |
| | Frequency Setup | 300 Hz | | | | |
| | | 600Hz | | | | |
| | | 1200Hz | | | | |
| | | 2400Hz | | | | |
| | | High | | | | |
| | | Frequency Adjust | | | | |
| | Init Effect Positions | Pan | 0-255 | | | |
| | | : | | | | |
| | | Dimmer Fine | 0-255 | | | |
| | Screen Settings | Display Intensity | 1-10 | | | |
| | | Screen Saver Delay | Off-10min. | | | |
| | | Touchscreen Lock | Off-10min. | | | |
| | | Recalibrate Touchscreen | | | | |
| | | Display Orientation | Normal | | | |
| | | | Inverted | | | |
| | | | Auto | | | |
| | Temperature Unit | °C, °F | | | | |
| | Fan Settings | Fan mode | Auto | | | |
| | | | High | | | |
| | | | Quiet | | | |

| Tab | Level 1 | Level 2 | Level 3 | Level 4 | Level 5 | Level 6 |
|---|-----------------------|----------------------------------|--------------------|---------|-------------|-------------|
| | | Quiet - Blackout Fan Off | On, Off | | | |
| | Dimmer Curve | Linear | | | | |
| | | Square Law | | | | |
| | | Super Square Law | | | | |
| | Gobo Indexing | Max. Speed & ShortCut | | | | |
| | | Follow Speed & Direction | | | | |
| | | Max. Speed & Follow Dir. | | | | |
| | Date & Time Settings | | | | | |
| | Focus Tracking | Off, On | | | | |
| | Default Settings | | | | | |
| | Password Protection | Off, On | | | | |
| | Reset Web Password | | | | | |
| | | | | | | |
| Manual Control | Reset Functions | Total System Reset | | | | |
|  | | Pan/Tilt reset | | | | |
| | | System Reset w/o P/T | | | | |
| | | Pan Reset | | | | |
| | | Tilt Reset | | | | |
| | | Color System Reset | | | | |
| | | Gobo/Eff. Wh. Reset | | | | |
| | | Optics/Prism/Frost Res. | | | | |
| | | Iris Reset | | | | |
| | Manual Effect Control | Pan | 0-255 | | | |
| | | : | | | | |
| | | Dimmer Fine | 0-255 | | | |
| | | | | | | |
| Stand -Alone | Test Sequences | Dynamic Mode | | | | |
|  | | Static Mode | Pan | 0-255 | | |
| | | | Tilt | 0-255 | | |
| | | | Zoom | 0-255 | | |
| | | | Focus | 0-255 | | |
| | MusicTrigger | Off, On | | | | |
| | Preset Playback | None | | | | |
| | | Test | | | | |
| | | Prog. 1 | | | | |
| | | Prog. 2 | | | | |
| | Play Program | Play Program 1 | | | | |
| | | Play Program 2 | | | | |
| | Edit Program | Edit Program 1 | Start Step | 1-80 | | |
| | | Edit Program 2 | End Step | 1-80 | | |
| | | | Edit Program Steps | Step 1 | Pan | 0-255 |
| | | | | : | : | |
| | | | | : | Dimmer Fine | 0-255 |
| | | | | : | Step Time | 0-25,5 sec. |
| | | | | Step 80 | Pan | 0-255 |
| | | | | | : | |
| | | | | | Dimmer Fine | 0-255 |
| | | | | | Step Time | 0-25,5 sec. |
| | | | | | | |
| Service | Adjust DMX Values | Pan | 0-255 | | | |
|  | | : | | | | |
| | | Dimmer Fine | 0-255 | | | |
| | Calibrations | Calibrate Effects | Pan | 0-255 | | |
| | | | Tilt | 0-255 | | |
| | | | Rot. Gobo Wheel | 0-255 | | |
| | | | R. Gobo Index 1 | 0-255 | | |

| Tab | Level 1 | Level 2 | Level 3 | Level 4 | Level 5 | Level 6 |
|-----|-----------------------|---------------------------|-----------------|---------|---------|---------|
| | | | : | : | | |
| | | | R. Gobo Index 8 | 0-255 | | |
| | | | Static Gobo | 0-255 | | |
| | | | Colour Wheel | 0-255 | | |
| | | | Cyan | 0-255 | | |
| | | | Magenta | 0-255 | | |
| | | | Yellow | 0-255 | | |
| | | | Prism 1 | 0-255 | | |
| | | | Prism 2 | 0-255 | | |
| | | | Prism Rotation | 0-255 | | |
| | | | Zoom | 0-255 | | |
| | | | Focus | 0-255 | | |
| | | | Iris | 0-255 | | |
| | | | Frost 1 | 0-255 | | |
| | | | Frost 2 | 0-255 | | |
| | | Calibrate Pan/Tilt EMS | | | | |
| | | Load Default Calibrations | | | | |
| | Rotating Gobos Change | Gobo Carousel 1 | G1-Mg | | | |
| | | | G2 | | | |
| | | | : | | | |
| | | | G8 | | | |
| | | | Gobo Offset | 0-255 | | |
| | LEDs Measure | | | | | |
| | Update Software | | | | | |

6. Control menu

The Robin Forte is equipped with the QVGA Robe touch screen with battery backup which allows you to set the fixture's behaviour according to your needs, obtain information on its operation, control all range of effects and program it in stand-alone mode.

The fixture's menu can be controlled either by the control buttons or directly by touching the icon.

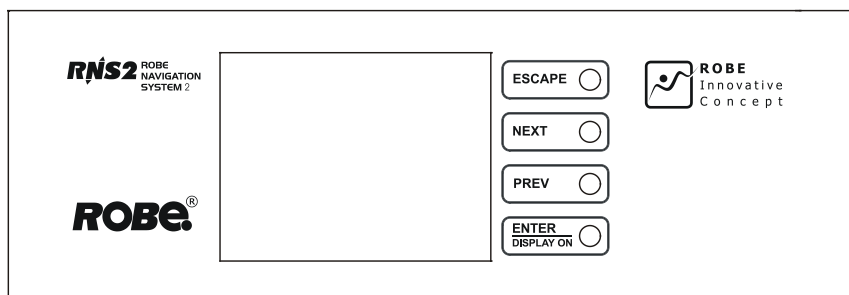

Control buttons on the front panel













[ESCAPE] button used to leave the menu without saving changes.

[NEXT] , [PREV] buttons for moving between menu items and symbols, adjusting values.

[ENTER/Display On] button used to enter the selected menu (menu item) and to confirm adjusted value.

If the fixture is disconnected from mains, the button switches the touch screen on.

Icons used in the touch screen menu:

-  - [back arrow] used to move back to the previous screen (menu).
-  - [up arrow] used to move up on the previous page.
-  - [down arrow] used to move down on the next page.
-  - [confirm] used to save adjusted values, to leave menu or to perform desired action.
-  - [cancel] used to leave menu item without saving changes.
-  - [confirm+copy] used to save adjusted values and copy them to the next prog. step.
-  - [warning icon] used to indicate some error which has occurred in the fixture.
-  - [Ethernet] used to indicate Ethernet connected.
-  - [menu rotation] used to rotate menu 180 degrees from current orientation.
-  - [slider control] used to recall slider system for setting desired value.
-  - [keyboard control] used to recall keyboard system for setting desired value.
-  - [air filters cleaning] used to signal that cleaning period of the air filters elapsed.

After switching the fixture on, the touch screen shows the screen with the ROBE logo.

Type of used LED engine in the fixture is displayed on the bottom line of the screen:

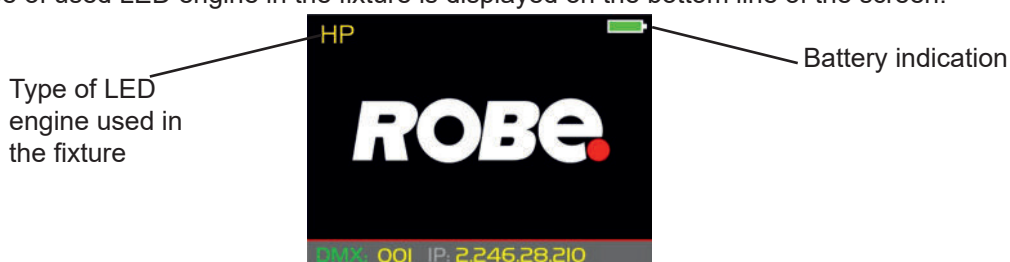

HP - High Performance Engine for maximum light output and optimal colour characteristics.

HCF - High Colour Fidelity Engine for the best light quality and colour reproduction.

The type of used LED engine is displayed if the fixture is disconnected from power as well.

Touch any part of the screen or press the [ENTER/Display On] button to display the initial screen with the current stored DMX address:

Note: The green icon at the top right corner of the screen indicates the level of the display battery charging. If the whole icon is green, the battery is fully charged while the red icon indicates exhausted battery. The battery charges during fixture operation, its charging lasts cca 6 hours.

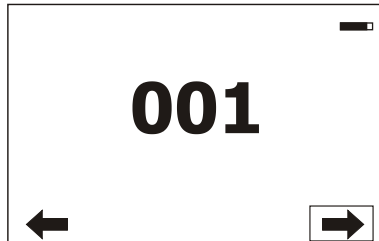

We recommend that the fixture should be in operation at least 7 hours per week to keep the battery fully charged. If you switch the fixture on and this screen will not appear till 1 minute, switch the fixture off and on again. If the screen lights, the battery is exhausted. In case the screen still does not light, the battery is faulty.

This is also indicated by an error message "Faulty battery" and if such an error message appears the battery should be replaced immediately. The lifetime of the battery is highly dependent on ambient temperature (and consequently on base temperature). If the maximum ambient temperatures (as recorded and displayed in menu: Information -> Fixture Temperatures -> Ambient Temperature -> Maximum NonRes.) are kept within the specified limits, the battery should last for at least two years. Should the ambient temperatures exceed the specified maximum temperature, the lifetime of the batteries could be considerably shortened even up to just one year or less and also result in physical damage (battery leakage) or unreliable fixture functions.

Damage caused by batteries failed due to exceeded maximum ambient temperature cannot be claimed under warranty terms.

Touch the green arrow at the bottom right corner of the screen or press the [ENTER/Display On] button to enter the "Address" menu.

Each item (such as a Tab, menu item, text box, icon) may be selected from a screen by simply touching the item in the list or by pressing the [NEXT] or [PREV] buttons to scroll through list items. With each press, the next item is highlighted. Press [ENTER/Display On] to select the highlighted item.

Before first fixture operation, set current date and time in the menu "Date & Time Settings" (menu path: Personality--> Date & Time Settings).

6.1 Tab "Address"



DMX Address - Select the menu to set the DMX start address.

DMX Presets - The menu item offers you two DMX modes (Mode 1-44 channels, Mode 2-45 channels).

Ethernet Settings* - The menu allows all needed settings for the Ethernet operation

Ethernet Mode

Disable - The option disables Ethernet operation.

Artnet - Fixture receives Artnet protocol

gMAI - Fixture receives MANet 1 protocol

gMA2 - Fixture receives MANet 2 protocol

sACN - Fixture receives sACN protocol

Ethernet To DMX - Fixture receives protocol from the Ethernet input and sends DMX data to its DMX output (fixture works as an "Ethernet/DMX converter", next fixture can be connected to its DMX output and you can build a standard DMX chain by connecting another fixtures. Only one fixture has to be connected to the Ethernet.

IP Address/Net Mask - Select this menu to set IP address. IP address is the Internet protocol address. The IP uniquely identifies any node (fixture) on a network.

There cannot be 2 fixtures with the same IP address on the network!

Default IP Address -Preset IP address, you can set up only first byte of IP address (2 or 10) e.g. **002**.019.052.086.

Custom IP Address - The option enables to set up all bytes of IP address.

Net Mask - The option enables to set up all bytes of Net Mask.

ArtNet Universe - Use this item to set a Universe (0-255). The Universe is a single DMX 512 frame of 512 channels.

MANet Settings - Use this menu to set parameters for MANet operation.

MANet Universe I/II - The value of this item can be set in range 1-256.

MANet Session ID - The value of this item can be set in range 1-32.

sACN Settings - Use this menu to set parameters for sACN operation.

sACN Universe - The value of this item can be set in range 1-32000.

Ethernet as Backup - If the function is Enabled, the fixture automatically switches to the Ethernet input for signal receiving in case of DMX signal loss. Correct protocol has to be set in the menu " Ethernet Mode".

6.2 Tab "Information"



Fixture Times - The menu provides readouts of fixture and LED module operation hours.

Power On Time Hours - Select this menu to read the number of fixture operation hours.

Total Hours - The item shows the total number of the operation hours since the Robin Forte has been fabricated.

Resetable Hours - The item shows the number of the operation hours that the Robin Forte has been powered on since the counter was last reset.

In order to reset this counter to 0, touch the text box next to the item "Resetable Hours:"

LED On Time - Select this menu to read the number of LEDs operation hours.

Total Hours - a total time of the LEDs module operation during which a dimmer intensity was > 0%.

Adaptive Hours - a relative time of the LEDs module operation during which a dimmer intensity was > 0%. (e.g. if dimmer = 20% for one hour, the adaptive time is 0.2 hour, if dimmer = 100% for one hour, the adaptive time is 1 hour).

Air Filters - Regular cleaning of the air filters is very important for the fixture's life and performance.

Bild-up of dust, dirt and fog fluid residues reduces the fixture's light output and cooling ability.

The two items of this menu help you to keep cleaning period of the air filters.

Alert period - Cleaning schedule for the fixture depends on the operating environment.

It is therefore impossible to specify accurate cleaning interval. This item allows you to change the cleaning interval of the air filters. This "alert" value is 300 hours and it is set as default. Inspect the fixture within its 300 hours of operation to see whether cleaning is necessary. If cleaning is required, clean all air filters and change the value in this menu on acceptable level. Min. level of alert period is 10 hours, max. is 300 hours.

Elapsed Time - The item allows you to read the time which remains to cleaning air filters.

The time period is set in the menu mentioned above.

Expired time period is signalled by a negative mark (-) at the time value and a warning icon on the display.

Clean the filters and reset this menu item (by touching the text box next to the item "Elapsed Time").

Fixture Temperatures - The menu is used to view temperatures of the fixture's inside.

LEDs temperature - The menu shows temperature on the LED PCB in the light source

Current - A current temperature of the LED PCB.

Maximum NonRes. - A maximum temperature of the LED PCB since the fixture has been fabricated.

Maximum Res. - A maximum temperature of the LED PCBs since the counter was last reset.

In order to reset some counter to 0, touch desired text box under item "Max.Res."

Driver Temperature - The menu shows temperature on the LEDs control PCB in the fixture head.

Current - A current temperature on the LEDs control PCB.

Maximum NonRes. - A maximum temperature on the LEDs control PCB since the fixture has been fabricated.

Maximum Res. - A maximum temperature on the LEDs control PCB since the counter was last reset.

In order to reset this counter to 0, touch the text box next to the item "Maximum Res."

Ambient Temperature - The menu shows temperature in the fixture base .

Current - A current temperature in the fixture base.

Maximum NonRes. - A maximum temperature in the fixture base since the fixture has been fabricated.

Maximum Res. - A maximum temperature in the fixture base since the counter was last reset.

In order to reset this counter to 0, touch the text box next to the item "Maximum Res."

Base Temperature - The menu shows temperature on the display PCB in the fixture base.

Current - A current temperature on the display PCB.

Maximum NonRes. - A maximum temperature on the display PCB since the fixture has been fabricated.

Maximum Res. - A maximum temperature on the display PCB since the counter was last reset.

In order to reset this counter to 0, touch the text box next to the item "Maximum Res."

DMX Values - The menu items allows you to read DMX values of each channel received by the fixture.

Wireless State - The menu serves for reading of the wireless operation status.

Unlink Wireless Adaptor - The item serves for unlinking the fixture from a DMX transmitter.

If the wireless module is not installed in the fixture, message "Wireless Module Not Installed" will appear.

Power Channel State - Select this item to see current setting of the functions, which can be set by menu items in "Personality" as well as by DMX command at channel "Power/Special functions".

Colour Functions State - Select this item to see current setting of the colour functions, which can be set by menu items in "Personality" as well as by DMX command at channel "Colour functions".

Software Version - Select this item to read the software version of the fixture processors:

Display System - a display processor on the display board in the fixture base

Module M - a pan/tilt processor

Module L - a LEDs control processor

Module O - a focus/zoom/frost control processor

Module G - a rot. gobo/static gobo wheel control processor

Module C - a colour wheel and CMY control processor

Module I - an iris control processor

Product IDs - The menu is used to read the MAC Address ,RDM UID and RDM Label.

LED Module Info - Use this menu to read LEDs module information.

First Module Assembly - Use the item to read initial information about the LEDs module installed in the fixture. The fixture has to be connected to mains to read the values in the menu items.

Serial Number/ Device UID - a serial number of the LEDs module/RDM UID of the fixture.

Installation Date/Time - a date/time of the first installation of the LEDs module to a some Forte device.

Intensity - an original intensity of the LEDs module in percentages (100%).

LEDs On Time Total/Adaptive - Total: a total time of the LEDs module operation during which the dimmer intensity was > 0%.

Adaptive: a relative time of the LEDs module operation during which the dimmer intensity was > 0% (e.g. if dimmer = 50% for one hour, the adaptive time is 0.5 hour, if dimmer = 100% for one hour, the adaptive time is 1 hour).

Actual Module Info - Use the item to read current information about the LEDs module installed in the fixture.

Serial Number/ Device UID - a serial number of the LEDs module/RDM UID of the fixture.

Measurement Date/Time - a date/time of running the procedure "LEDs Measure" in the tab Service.

Intensity - the item shows a light intensity of the LEDs module measured after running the procedure "LEDs Measure" in the tab Service. The light intensity is displayed in percentages in relation to the initial intensity of the new LEDs module (initial intensity=100%).

LEDs On Time Total/Adaptive - Total: a total time of the LEDs module operation during which the dimmer intensity was > 0%.

Adaptive: a relative time of the LEDs module operation during which the dimmer intensity was > 0% (e.g. if dimmer = 50% for one hour, the adaptive time is 0.5 hour, if dimmer = 100% for one hour, the adaptive time is 1 hour).

Assembly History - Use the item to read a history of the LEDs module installed in the fixture (its serial number, RDM UID of fixture at which was installed and date/time of installation). Up to 31 records can be saved in the menu item.

Intensity History - Use the item to read a history of light intensity of the LEDs module installed in the fixture.

Serial Number/ Device UID - a serial number of the LEDs module/RDM UID of the fixture.

Measurement Date/Time - a date/time of running the procedure "LEDs Measure" in the tab Service.

Intensity - the item shows a light intensity of the LEDs module measured after running the procedure "LEDs Measure" in the tab Service. The light intensity is displayed in percentages in relation to the initial intensity of the new LEDs module (initial intensity=100%) .

Up to 31 records can be saved in the menu item.

LED Modules History - Use the item to read a history of the LEDs modules installed in the fixture (their serial numbers and date/time of installation).

Up to 31 records can be saved in the menu item.

View Logs - Use this menu to read fixture's data which have been recorded during fixture operation. This collected data allows easier troubleshooting.

Fixture Errors - Use this menu to read fixture errors which have occurred during fixture operation.

Fixture States - In the menu are recorded fixture states as power on and power off.

Fixture Positions - In the menu are recorded installation positions of the fixture:

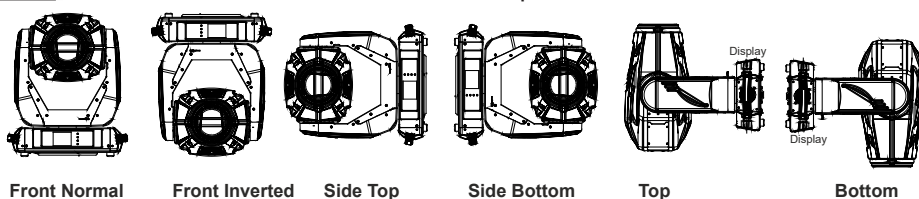

Fixture Temperatures - In the menu are recorded temperatures which have exceeded defined levels.

Note: The log buffer can contain max. 8000 records. If the buffer is full, old data will be overwritten.

6.3 Tab "Personality"



User mode - The Robin Forte allows you to recall two user settings. After switching the fixture on for the first time, the User A settings is active. Now all changes made in the "Personality" menu, "Addressing" menu and the "Music Trigger" and "Preset Playback" items from the "Stand-alone" menu are saved to the User A settings. If you now select the User B settings, from this moment the changes made in these menus will be saved to the User B settings. After switching the fixture off and on, the User B setting is active. In this way you may use the two fixture operating behaviours.

User A Settings - the function recalls the user A settings.

User B Settings - the function recalls the user B settings.

DMX Presets - Use the menu to select desired channel mode.

Mode 1 - 44 control channels

Mode 2 - 45 control channels

View Selected Preset - Use the menu to display channels included in the selected mode.

DMX Input - Use the menu to select mode of DMX signal receiving.

Wired - DMX signal is received by means of the standard DMX cable.

Wireless - DMX signal is received by means of the inbuilt wireless module.

Wireless In/XLR Out - the fixture receives wireless DMX and sends the signal to its wired DMX output.

The fixture behaves as "Wireless/Wired" adapter.

The options "Wired" and "Wireless" are also stated in DMX chart (channel Power/Special functions).

Note. If the wireless module is not installed in the fixture, the following message will appear:

DMX Input Set to Wired

Wireless Module Missing

If the fixture is not connected to mains, the message "Not Available In Offline Mode" will appear after entering the menu DMX Input. To enter this menu, the fixture has to be connected to mains.

Pan/Tilt Settings - Use the menu set behaviour of both pan and tilt movements.

Pan Reverse - The item allows to invert pan movement.

Tilt Reverse - The item allows to invert tilt movement.

Pan/Tilt Feedback - The item allows to return the moving head to the required pan/tilt position after changing the position by an external force if this option is set on.

Note. Be careful, the Pan/Tilt Feedback should be permanent On, the option Off is not suitable for standard operation and the head of the fixture can be damaged!

Pan/Tilt mode - Use this menu to set the mode of the pan/tilt movement

Time mode – The pan and tilt will move with different speeds and they will come at the same time to the end point of their tracks (pan and tilt use their optimal speeds).

Time of the pan/tilt movement (25.5 sec. max.) is set by the channel "Pan/Tilt speed, Pan/Tilt time".

Speed Mode - Both Pan and tilt will move with the same speed as adjusted at the channel "Pan/Tilt speed, Pan/Tilt time".

Pan/Tilt Reset - This menu item allows you to choose a way of pan/tilt reset after switching the fixture on

With P/T - With pan and tilt - the item will reset both pan and tilt simultaneously after switching the fixture on.

Without P/T - Without pan and tilt reset after switching the fixture on. The pan and tilt reset can be run by the menu Manual Control (Manual Control --> Reset Functions) or by DMX commands.

Tilt then Pan - the item will reset pan and tilt sequentially, first tilt, then set tilt to DMX 128 and reset pan.

Pan then Tilt - the item will reset pan and tilt sequentially, first pan, then set pan to DMX 128 and reset tilt.

Note: DMX triggered pan/tilt related reset commands on the channel Power/Special functions always behave in this way:

"Total fixture reset (including pan/tilt)" - resets all functions including pan and tilt. Pan and tilt always are reset, either simultaneously or sequentially.

"Total fixture reset (without pan/tilt)" - resets all functions except pan and tilt. When set to simultaneous reset (the standard reset With P/T), the head will position itself briefly into defined position for reset of the optical system.

"Pan and Tilt reset" - pan and tilt always are reset, either simultaneously or sequentially (depends on setting in the display menu Personality --> Pan/Tilt Reset).

"Pan reset" - resets pan, tilt is static in the position of a tilt DMX value received when pan reset was received.
"Tilt reset" - resets tilt, pan is static in the position of a pan DMX value received when tilt reset was received.

Pan/Tilt EMS - Built-in electronic motion stabilizer ensures precise position of the fixture's head during its movement and also reducing its swinging when the truss shakes.

Microphone Sensitivity - Enter the menu if you want to adjust the microphone sensitivity from 1 (max.) to 20 (min.).

Blackout Settings - Use the menu if you need to close the light output under certain conditions which are described below

Blackout During MC - Blackout during movement correction. Set this option On if you wish to close light output during the time when the head goes to its correct position from which has been changed by an external force.

Active Blackouts - Use this menu if you wish to close the light output during effect changes.

Pan/Tilt Moving - The menu item enables to close light output while the pan/tilt DMX values are changing.

Colour Wheel Moving - The menu item enables to close light output while colour wheel is moving.

Frequency Setup - The function allows you to set the PWM (Pulse Width Modulation) output frequency of LEDs to 300Hz, 600Hz, 1200Hz, 2400Hz or High.

Frequency Adjust - The menu item allows you fine adjustment of the LED frequency around selected frequency.

Init Effect Positions - Use the menu to set all effects to the desired positions at which they will stay after switching the fixture on without DMX signal received.

Screen Settings - Use this menu to change the touch screen settings.

Display Intensity - The item allows to control the intensity of the screen (1-min., 10-max.).

Screen saver Delay - The item allows you to keep the screen on or to turn it off automatically after 1-10 minutes after last touch (or pressing any button on the control panel).

Touchscreen Lock - The item allows you to lock the screen after last touch (or pressing any button on the control panel). The time delay can be set in range of 1-10 minutes. To unlock the screen, press the [ENTER/Display On] button.

Recalibrate Touchscreen - The item starts calibration of the touch screen. Follow the instructions on the screen.

Display Orientation - The menu allows to change display orientation.

Normal - Standard display orientation if the fixture is placed horizontally (e.g. on the ground).

Inverted - Inverted orientation (needed if the fixture is hanging on the truss).

Auto - The option activates a gravitation sensor for automatic screen orientation.

Note: **Auto** option is set as default. You change the display orientation by touching the icon  on the display, and the option set in the "Display Orientation" menu is temporarily overridden.

Temperature unit - Use the menu item to change temperature unit from °C to °F.

Fan Settings - Use the menu to set fans operation mode.

Fan Mode - Use the menu to set the fixture fans to max. power mode (option "**High**") or to the auto-control mode (option "**Auto**"). The third option "**Quiet**" allows you to set desired fan noise. The light output of the fixture is reduced at low speeds of fans.

Quiet - Blackout Fan Off - The menu item allows you to stop all fans in the fixture (option "**On**") when its light output is closed (shutter in range of 0-31 DMX or dimmer in 0 DMX).

Dimmer Curve - Use the menu to select desired dimmer curve: Linear, Square Law or Super Square Law.

Gobo Indexing - The following three options define transition from gobo rotation to gobo indexing.

Max. Speed & Shortcut - Gobo goes from its rotation to desired indexed position with max. speed and via shortest track.

Follow Speed & Direction - Gobo goes from its rotation to desired indexed position with current speed and keeps a direction of rotation.

Max. Speed & Follow Dir. - Gobo goes from its rotation to desired indexed position with max. speed and keeps a direction of rotation.

Date & Time Settings - Use this menu to set current date and time for the fixture log system (menu "View Logs"). Set this menu items before first fixture operation.

Focus Tracking - This feature provides automatic sharpness re-adjustment during zoom movement, after an initial sharpness has been set by the operator by setting the focus channel and enabling the FocusTracking. The

Focus Tracking feature is done via automatic movement of focus element, taking into account several internal parameters, zoom position being one of them. To utilize the Focus Tracking, make sure to enable the Focus Tracking, set the Zoom to value 200 and adjust Focus to desired sharpness. Then, while keeping Focus value untouched, you can move the Zoom. Fixture will automatically keep the projection at the desired sharpness as much as possible. You can also re-adjust the Focus value over time if needed. When switching between static gobo wheel, rotating gobo wheel and an empty aperture, the Focus Tracking will adjust the internal parameters, therefore providing desired sharpness by adjusting the Focus might be required. If you use both Static gobo wheel and rotating gobo wheel without further adjusting the Focus value, rotating gobo wheel will be automatically used for Focus Tracking 's focusing.

Default Settings - The menu item allows to set all fixture parameters in this menu to the default (factory) values except items "DMX Input".

Password Protection - allows to enter password in order to prevent unauthorized person from changing setting of the fixture. Password is set to 7623 and cannot be changed.

Reset Web Password - The menu item allows you to reset a password for access to the Robe Ethernet Access Portal (REAP), default password: 2479, user: robe.

6.4 Tab "Manual Control"



Reset Functions - The menu allows to reset the fixture either per function modules or all modules together.

Total System Reset - The item resets all function modules.

Pan/Tilt Reset - The item resets pan and tilt.

Pan Reset - The item resets a pan.

Tilt Reset - The item resets a tilt.

Colour System Reset - The item resets colour wheel and CMY+CTO system.

Gobos Reset - The item resets rotating gobo wheels.

Optics/Prism/Frost Res. - The item resets a zoom, focus, prism and a frost module.

Iris Reset - The item resets an iris module.

Manual Effect control - Use the menu to control all fixture channels by means of the control panel.

6.5 Tab "Stand-alone"



Test Sequences - Use the menu to run a test/demo sequences without an external controller, which will show you some possibilities of using Robin Forte.

Dynamic Mode - This mode uses all Robin Forte functions including pan/tilt movement and therefore is good for a complete introduction of the fixture.

Static Mode - This mode is suitable for projections on the wall, ceiling or ground without any pan/tilt movement. Adjust the pan, tilt, zoom and focus to desired positions and start test sequences by touching the green ► icon.

Music Trigger - Use the item to activate the sound control of the running program via the built-in microphone.

Preset Playback - This menu allows you to select the program which will be played in a loop after switching the fixture on (the option is commonly used in a stand-alone operation without an external controller).

None - The option disables "Presetting playback" function.

Test - The option starts the test sequences.

Prog. 1 - The option starts user program No. 1.

Prog. 2 - The option starts user program No. 2.

Play program - Use the menu to run desired program in a loop.

Play Program 1 - The option starts user program No.1.

Play Program 2 - The option starts user program No. 2.

Edit Program - Use the menu to create or to edit desired program. The Robin Forte offers 2 free programs, each up to 80 steps.

Edit Program 1 - The option allows you to edit user program No.1.

Edit Program 2 - The option allows you to edit user program No.2.

To edit program:

1. Touch the item which you want to edit ("Edit Program 1" - "Edit Program 2").
2. Touch the item "Edit Program Steps".
3. Touch the item "Step 1".
4. From the list of effects touch desired effect and set its value. Browse through the list by touching the [up arrow] and [down arrow] and set all desired effects.

An item "Step Time" (value of 0-25.5 sec.) is the time during which effects last in the current step

5. Save adjusted effects to the current step by touching the [confirm] or save and copy them to the following step by touching the [confirm+copy]. By touching the text box "Preview" next to the current program step you can view created scene.

6. Repeat the steps 4 and 5 for next program steps.

7. After editing desired program steps, adjust the length of the program by touching the text boxes "Start Step" and "End Step".

Meaning of the icons used in the "Edit Program" menu:

↓ - moves down on the next page

✓ - saves adjusted values and leaves menu

↑ - moves up on the previous page

✓ - saves values to the current step and copy them to the following prog. step

✗ - leaves menu without saving values

6.6 Tab "Service"



Adjust DMX Values - The menu allows you to set all effects to desired positions before fine calibration of the effects .

Calibrations - This menu enables fine calibration of fixture effects and download default calibration values.

Calibrate Effects - The menu allows the fine adjustment of effects.

Pan- a pan position fine adjustment (value range: 0-255)

Tilt - a tilt position fine adjustment (value range: 0-255)

Rot. Gobo Wheel - a carousel of rotating gobos fine movement (value range: 0-255)

R. Gobo Index 1 - a fine movement of the rotating gobo 1 (value range: 0-255)

R. Gobo Index 2 - a fine movement of the rotating gobo 2 (value range: 0-255)

R. Gobo Index 3 - a fine movement of the rotating gobo 3 (value range: 0-255)

R. Gobo Index 4 - a fine movement of the rotating gobo 4 (value range: 0-255)

R. Gobo Index 5 - a fine movement of the rotating gobo 5 (value range: 0-255)

R. Gobo Index 6 - a fine movement of the rotating gobo 6 (value range: 0-255)

R. Gobo Index 7 - a fine movement of the rotating gobo 7 (value range: 0-255)

R. Gobo Index 8 - a fine movement of the rotating gobo 8 (value range: 0-255)

Static Gobo - a static gobo wheel fine movement (value range: 0-255)

Colour Wheel - a colour wheel fine movement (value range: 0-255)

Cyan - a cyan flag fine movement (value range: 0-255)

Magenta - a magenta flag fine movement (value range: 0-255)

Yellow - an yellow flag fine movement (value range: 0-255)

Prism 1 - a prism fine movement in relation to stop (value range: 0-255)

Prism 2 - a prism fine movement in relation to optic axis (value range: 0-255)

Prism Rotation - a prism fine rotation (value range: 0-255)

Zoom - a zoom module fine movement (value range: 0-255)

Focus - a focus module fine movement (value range: 0-255)

Iris - an iris fine movement (value range: 0-255)

Frost 1 - a frost fine movement in relation to stop (value range: 0-255)

Frost 2 - a frost fine position movement in relation to optic axis (value range: 0-255)

Calibration of the effects via the control board

1. Disconnect DMX controller from the fixture and enter the "Calibrate Effects" menu.
2. Use the [up arrow] and [down arrow] to find "Pan" and touch it to enter the fine effect adjustment screen.
3. Set desired value and save it by touching the [confirm].
4. Repeat steps 2 and 3 for next item.
5. After calibrating all effects, touch the [confirm] to save all adjusted values and reset the fixture.

Calibration of the effects via the DMX controller

1. Connect DMX controller to the fixture and enter the "Calibrate Effects" menu.

Calibration protocol:

| Effect | Mode 1 | Mode 2 |
|-----------------|---------------|---------------|
| Pan | channel 36 | channel 37 |
| Tilt | channel 37 | channel 38 |
| Rot. Gobo Wheel | channel 38 | channel 39 |
| R. Gobo Index 1 | channel 39 | channel 40 |
| R. Gobo Index 2 | channel 40 | channel 41 |
| R. Gobo Index 3 | channel 41 | channel 42 |
| R. Gobo Index 4 | channel 42 | channel 43 |
| R. Gobo Index 5 | channel 43 | channel 44 |
| R. Gobo Index 6 | channel 44 | channel 45 |
| R. Gobo Index 7 | channel 45 | channel 46 |
| R. Gobo Index 8 | channel 46 | channel 47 |
| Static gobo | channel 47 | channel 48 |
| Colour wheel | channel 48 | channel 49 |
| Cyan | channel 49 | channel 50 |
| Magenta | channel 50 | channel 51 |
| Yellow | channel 51 | channel 52 |
| Prism 1 | channel 52 | channel 53 |
| Prism 2 | channel 53 | channel 54 |
| Zoom | channel 54 | channel 55 |
| Focus | channel 55 | channel 56 |
| Iris | channel 56 | channel 57 |
| Frost 1 | channel 57 | channel 58 |
| Frost 2 | channel 58 | channel 59 |

Calibrate Pan/Tilt EMS - This menu item allows calibration of the pan/tilt electronic motion stabilizer.

Important: during this calibration any external force must not influence the fixture and the surface at which the fixture stands (or truss if the fixture hangs) has to be without movement, shake, strokes etc.

Load Default Calibrations - The item loads default (factory) calibration values.

Rotating Gobos Change - This menu makes changing of rotating gobos in the fixture easier.

Gobo Carousel - The menu allows movement of rotating gobos on the gobo carousel to positions suitable for their changing.

G1-Mg - a movement of the gobo 1 (gobo holder with magnet) to the changing position.

G2 - a movement of the gobo 2 to the changing position.

:

G8 - a movement of the gobo 8 to the changing position.

Gobo Offset - a gobo offset setting. The function allows fine swiveling of the gobo holder. The set value is valid for all gobos on the gobo carousel.

LEDs Measure - This menu item runs a procedure which measures a light intensity of the LEDs module installed in the fixture. This procedure takes about 1 minute (message "LEDs Module Measurement" is displayed on the screen). During the procedure the fixture does not receive DMX signal, pan/tilt go to 128 DMX, a shutter is open and a dimmer is set at max. light intensity (255 DMX). All effects are taken out from the light beam.

The measured light intensity is recorded in the item Intensity in the menu LED Module Info:

Tab Information --> LED Module Info--> Actual Module Info --> Intensity

Tab Information --> LED Module Info--> Intensity History --> Intensity

The light intensity in the menu item Intensity is displayed in percentages in relation to the initial intensity of the new LEDs module (initial intensity=100%).

The LEDs Measure procedure should be run after every change of the LED light source.

Note: The fixture has to be connected to mains in order to run LEDs Measure procedure.

Update software - The menu item allows you to update software in the fixture.

The following items are required in order to update software:

- PC running Windows or Linux or macOS
- DSU file
- Flash cable RS232/DMX, P/N13050624 (if you want to use a serial port of PC)
- Robe Universal Interface or Robe Universal interface WTX (if you want to use an USB port of PC)

After the software updating the fixture will be set to default values.

The following items are required in order to update software:

- PC running Windows or Linux or macOS
- DSU file
- Flash cable RS232/DMX, P/N13050624 (if you want to use a serial port of PC)
- Robe Universal Interface or Robe Universal interface WTX (if you want to use an USB port of PC)

After the software updating the fixture will be set to default values.

To update software in the fixture:

1. DSU file is available from Robe web site at WWW.robe.cz.

File with extension zip is intended for Windows (used and tested from XP to W10 on 32/64bit systems).

File with extension tbz is intended for Linux (used and tested on Debian and Ubuntu 32/64bit).

File with extension dmg is intended for macOS (used and tested on OSX up to Sierra) XQuartz required, install it from <https://www.xquartz.org/>

Save the download file to a folder on your computer.

In case that you use windows, extract files in the zip file (e.g. DSU_RobinPainte_21091633.zip)

2. Disconnect the fixture from DMX controller.

3. If you use the flash cable RS232/DMX, connect a serial port of your computer with DMX input of the fixture by means of the cable.

If you use the Robe Universal Interface, connect a USB port of your computer with the Robe Universal Interface by means of the USB cable and DMX input of the fixture with the DMX output of the Robe Universal Interface via a DMX cable.

4. Switch the fixture to the update mode (Special -> "SW Upd "-> On).

Note: If you do not want to continue in the software update, you have to switch off and on the fixture to escape from the updating mode.

We recommend to cancel all running programs on your computer before starting the software update.

5. Double-click the software uploader file (e.g. DSU_RobinPainte_21091633.exe) in the extracted files. The Software Uploader program will run.

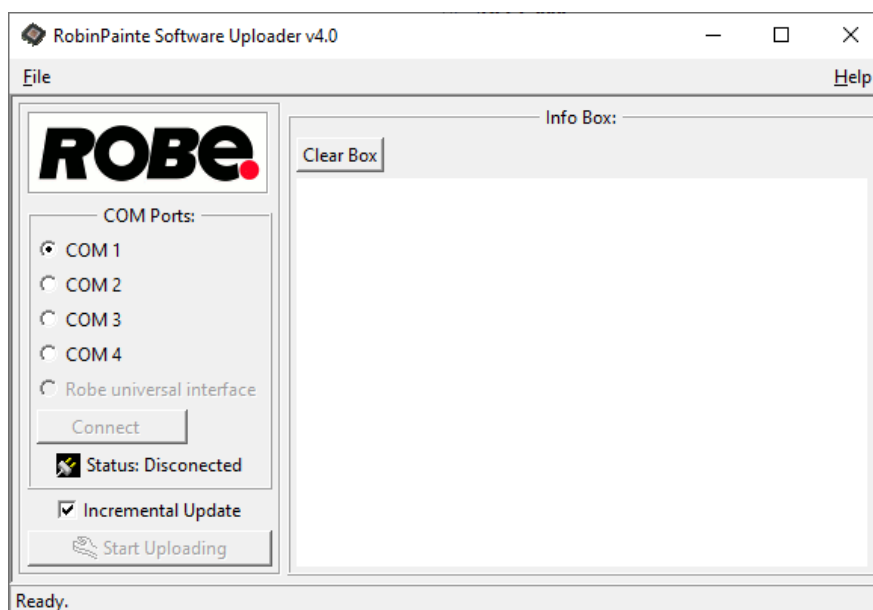

6. Select correct "COM " number if you use a Flash cable RS232/DMX or select "Robe Universal Interface " if you use the Robe Universal Interface/Robe Universal Interface WTX and then click on the "Connect" button.

7. If the connection is OK, click the "Start Uploading" button to start software uploading. It will take several minutes to perform software update.

If the option "Incremental Update" is not checked, all processors will be updated (including processors with the same software version).

If you wish to update only processors with new version of software, check the “Incremental Update box”. Avoid interrupting the process. Update status is being displayed in the "Info Box" window. When the update is finished, the line with the text “Fixture is successfully updated” will appear in this window.

In case upload process is interrupted (e.g. power loss), the fixture stays in “Updating mode” and you will have to repeat the software update again.

Another way, how to update software in the fixtures (especially large installation of fixtures) is to use the ROBE Uploader. It is a software for automatized software update of Robe fixtures. It takes advantage of RDM support).

For more information please see <https://www.robe.cz/robe-uploader/>.

7. RDM

This fixture supports RDM operation. RDM (Remote Device Management) is a bi-directional communications protocol for use in DMX512 control systems, it is the new open standard for DMX512 device configuration and status monitoring.

The RDM protocol allows data packets to be inserted into a DMX512 data stream without adversely affecting existing non-RDM equipment. By using a special „Start Code,“ and by complying with the timing specifications for DMX512, the RDM protocol allows a console or dedicated RDM controller to send commands to and receive messages from specific moving lights.

RDM allows explicit commands to be sent to a device and responses to be received from it.

The list of commands for Robin Painte Spot is the following.

| Parameter ID | Discovery command | SET command | GET command |
|-----------------------------|-------------------|-------------|-------------|
| DISC_UNIQUE_BRANCH | * | | |
| DISC_MUTE | * | | |
| DISC_UN_MUTE | * | | |
| DEVICE_INFO | | | * |
| SUPPORTED_PARAMETERS | | | * |
| SOFTWARE_VERSION_LABEL | | | * |
| DMX_START_ADDRESS | | * | * |
| IDENTIFY_DEVICE | | * | * |
| DEVICE_MODEL_DESCRIPTION | | | * |
| MANUFACTURER_LABEL | | | * |
| DEVICE_LABEL | | * | * |
| SENSOR_DEFINITION | | | * |
| SENSOR_VALUE | | | * |
| DISPLAY_INVERT | | * | * |
| DISPLAY_LEVEL | | * | * |
| PAN_INVERT | | * | * |
| TILT_INVERT | | * | * |
| DEVICE_RESET | | * | |
| DMX_PERSONALITY | | * | * |
| DMX_PERSONALITY_DESCRIPTION | | | * |
| STATUS_MESSAGES | | | * |
| STATUS_ID_DESCRIPTION | | | * |
| DEVICE_HOURS | | | * |
| PARAMETER_DESCRIPTION | | | * |
| ROBE_DMX_INPUT | | * | * |
| ROBE_WIRELESS_UNLINK | | * | |

RDM model ID for the Robin Painte Spot is 0x0127.

8. Error and information messages

Information icon



- Air Filters Cleaning

This icon signals that cleaning period of the air filters has elapsed and you have to clear air filter and reset the menu item "Elapsed Time".

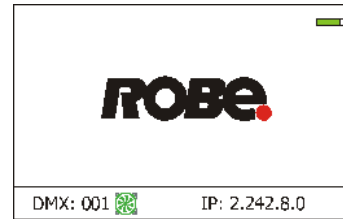

Errors

Error in the fixture is signalled by the yellow warning icon at the bottom line of the screen:



Touch the warning icon or press the [ESCAPE] button to display error messages.
List of error and information messages:

Pan Error 1

Pan sensor is not in a function state "connected".

Pan Error 2

Pan sensor is not in a function state "unconnected".

Pan Error 3

Pan feedback error.

Tilt Error 1

Tilt sensor is not in a function state "connected".

Tilt Error 2

Tilt sensor is not in a function state "unconnected".

Tilt Error 3

Tilt feedback error.

Colour Wheel Error 1

Magnetic/optic sensor was not detected.

Colour Wheel Error 2

Magnetic/optic sensor permanently detects colour wheel.

Prism Rot. Error 1

Magnetic/optic sensor was not detected at prisma wheel.

Prism Rot. Error 2

Magnetic/optic sensor permanently detects prism wheel

Prism Error 1

Impact to the mechanical end of the prism wheel track was not detected.

Prism Error 4

Incorrect detection of a prism wheel track. Impact to a mechanical obstruction was detected within running of the prism 1.

Iris Error 1

Impact to the mechanical end of the iris track was not detected.

Iris Error 4

Incorrect detection of a iris track. Impact to a mechanical obstruction was detected within running of the iris.

Frost Error 1

Impact to the mechanical end of the frost track was not detected.

Frost Error 4

Incorrect detection of a frost track. Impact to a mechanical obstruction was detected within running of the frost.

Zoom Error 1

Impact to the mechanical end of the zoom track was not detected.

Zoom Error 4

Incorrect detection of a zoom track. Impact to a mechanical obstruction was detected within running of the zoom.

Focus 1 Error 1

Impact to the mechanical end of the focus module track was not detected.

Focus Error 4

Incorrect detection of a focus track. Impact to a mechanical obstruction was detected within running of the focus module.

Gobo Carousel Error 1

Magnetic/optic sensor was not detected.

Gobo Carousel Error 2

Magnetic/optic sensor permanently detects gobo carousel.

Gobo Rotation Error 1

Magnetic/optic sensor was not detected on the rotating gobo on the gobo carousel.

Gobo Rotation Error 2

Magnetic/optic sensor permanently detects rotating gobo on the gobo carousel.

Static Gobo Error 1

Magnetic/optic sensor was not detected.

Static Gobo Error 2

Magnetic/optic sensor permanently detects static gobo wheel..

EEPROM Error

Hardware error of the EEPROM.

Recharge The battery

The battery on the display board needs to be charged. Let the fixture on for cca 6 hrs.

Battery Faulty. Replace it.

The battery on the display board is exhausted and should be replaced immediately.

Pan/Tilt EMS Cal. Error

The EMS system is not calibrated.

Pan/Tilt EMS Error

Control electronics cannot communicate with the EMS system.

Internal Error 1

Communication error between PCBs (error or noise was detected on communication wires)

Internal Error 2

Communication error (some PCB has failed or is disconnected (this PCB will show as N/A in menu --> Information --> Software versions) or error/noise was detected on communication wires)

Clean Air Filters

The message informs you that the item "Elapsed Time" in the "Fixture Information" menu is at 0 value. Clean air filter and reset this counter.

Overheated

The LED engine is overheated and light output is closed.

White 1 Short Error (White 2 Short Error/ White 3 Short Error/ White 4 Short Error)

Some white LEDs in the light source have short circuit or are disconnected.

White 5 Short Error (White 6 Short Error/ White 7 Short Error/ White 8 Short Error)

Some white LEDs in the light source have short circuit or are disconnected.

Suction LED Fan 1 Bad/ Suction LED Fan 2 Bad

The suction fan 1 (fan 2) at the LED engine is is disconnected from its control PCB or is faulty and should be replaced.

Exhaust LED Fan 1 Bad/ Exhaust LED Fan 2 Bad

The exhaust fan 1 (fan 2) at the LED engine is is disconnected from its control PCB or is faulty and should be replaced.

Positions of fans (and their control PCBs):

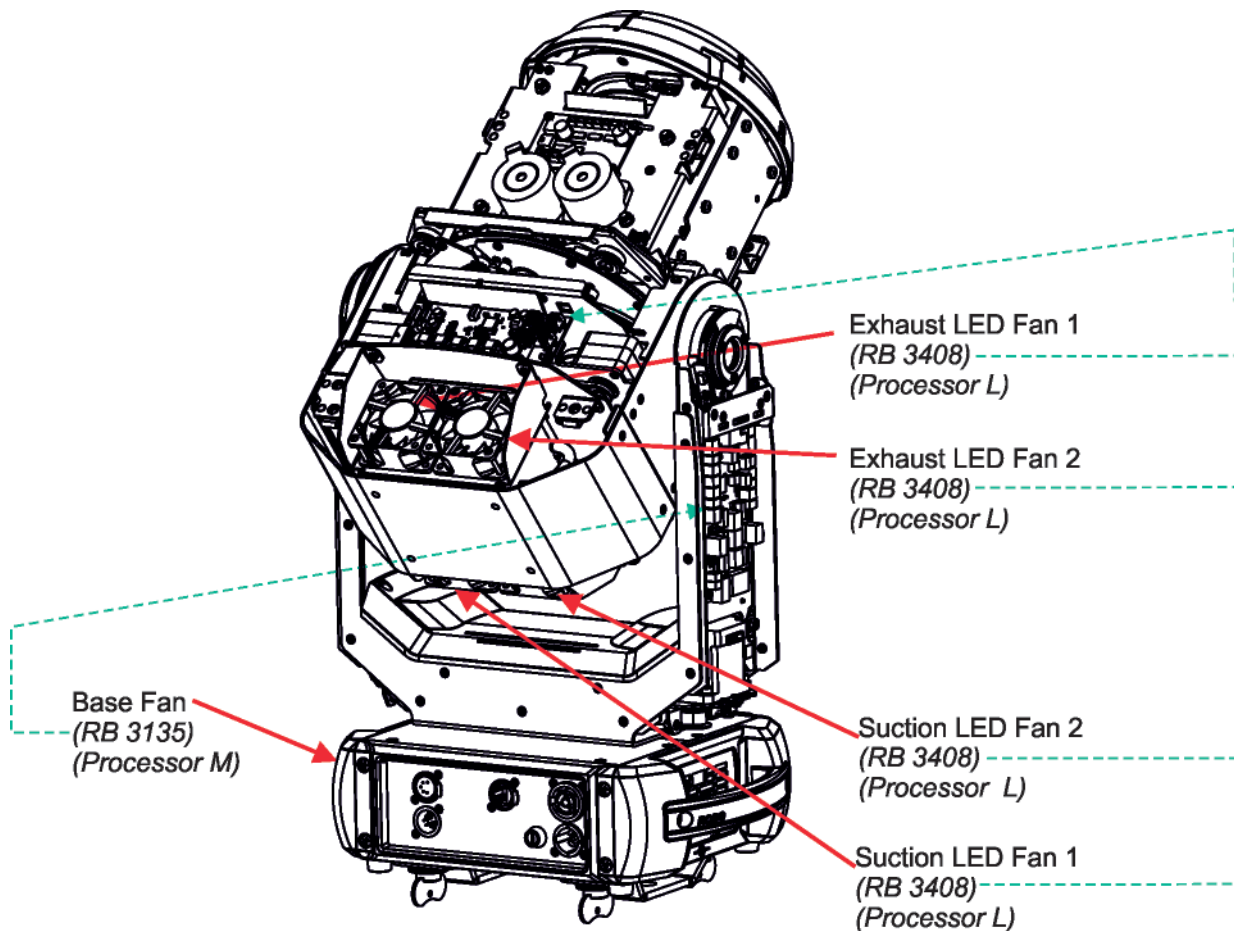

9. Robe Ethernet Access Portal (REAP)

The REAP allows you to display on your computer information about some fixture settings, operating conditions (e.g. temperature in the fixture) and error messages which were generated during fixture operation. Your computer needs to be connected to the fixture(s) through the means of Ethernet wired network and a network switch.

The Ethernet network connection (Local LAN) typically needs to be set to 2.x.x.x address, assuming that no other computer on the network contains such an address while keeping all ROBE fixtures in default IP settings.

For more information about REAP options, computer and fixture settings please see the REAP user manual at https://www.robe.cz/res/downloads/user_manuals/User_manual_REAP.pdf.

10. Technical Specifications

Electrical

Power supply: electronic auto-ranging
Input voltage range: 100-240V, 50-60Hz
Fuse: T 6.3A/250V ~
Max. power consumption: 440W (power factor 0.98)
Mains input: - max. 16A (US 13A)

Optic

Light source: TE™ 310W HP White LED Engine:
Colour temperature: 6500K
Fixture total lumen output: 12 000 lm (goniophotometer)
CRI 70, remotely selectable filter for CRI 90
Typical lumen maintenance: L70/B50 @ 50.000 hours
Light source warranty: 4 years or 20.000 hours

Colour wheel

9 dichroic filters (including one multicolour filter) + open

CMY colour mixing

Smooth CMY colour mixing system

Static gobo wheel

9 metal gobos

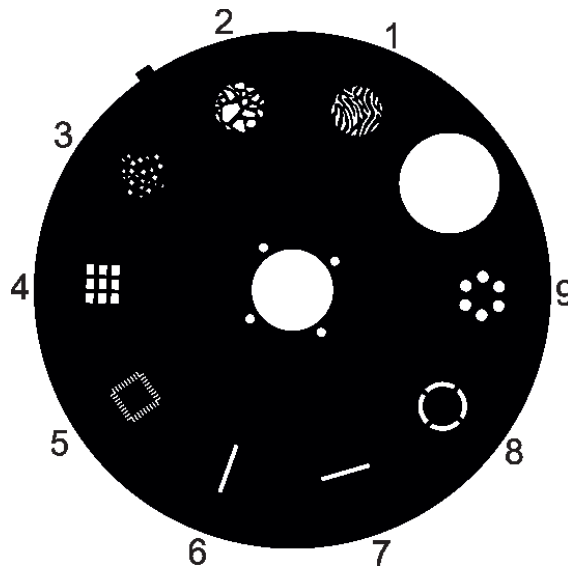

Rotating gobo wheel

8 glass gobos can be indexed and rotated in both directions at different speeds
Gobo wheel continuous rotation
Glass gobos: outside diameter= 15.8^{+0,15} mm, image diameter=12.5 mm, thickness=1.1-1.5 mm,
high temperature borofloat or better glass
"Slot&lock" system for easy replacement of gobos

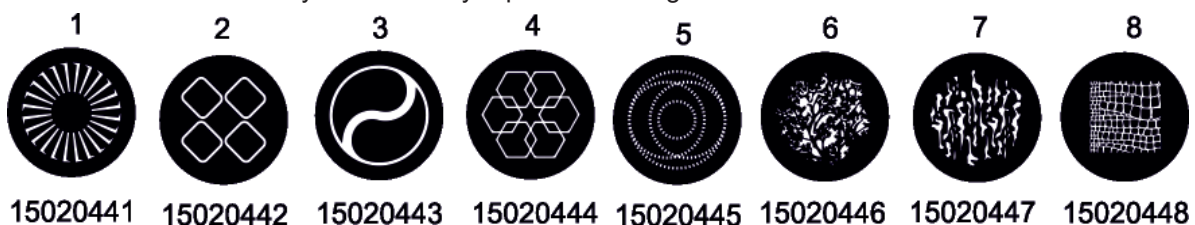

Prism

8-facet rotating prism with continuous rotation in both directions

Frost filter

Frost filter 5° installed, 1° frost filter enclosed

Zoom

Motorized zoom 8° - 48°

Focus

Motorized focus allows to focus beam from approx. 2 meters to infinity.

Iris

Motorized iris for different beam diameters

Strobe

Strobe effect with variable speed (0.3 - 20Hz)

Dimmer

Smooth dimmer from 0 - 100 %

Pan/Tilt

Pan movement range 540°
Tilt movement range 270°
16 bit movement resolution
Automatic Pan/Tilt position correction
Pan/Tilt electronic motion stabilizer
Remotely controllable speed of pan/tilt

Control

Graphic touch screen for fixture setting and addressing
Gravitation sensor for auto screen positioning
Battery backup of the touch screen
Readout fixture usage, receiving DMX values, temperatures, etc
Built-in analyzer for easy fault finding, error messages
Silent fans cooling,
Stand-alone operation
3 user editable programs, each up to 40 steps
Supported protocols: USITT DMX 512, RDM, ArtNet, MA Net, MA Net2, sACN
2 DMX mode (44/45 control channels)

Wireless DMX/RDM module type RW 001 (only wireless DMX version of the fixture)

Supported protocols: full RDM support, CRMX , W-DMX™ G2, G3,G4 and G4S
Operational frequency range: 2402-2480 MHz
Output power: 100 mW
Receiver sensitivity (0.1% BER): -93 dBm
Crystal Clock Frequency : 16.0 MHz

Max. number of fixtures in Ethernet IN/Out line

8

Connection

DMX data in/out: Locking 5-pin XLR
Ethernet In/Out: 2 x RJ 45 (Robin Painte Spot EP only)
Power IN: Neutrik powerCON TRUE1
Power OUT: Neutrik powerCON TRUE1

Rigging

Mounting points: 2 pairs of 1/4-turn locks
Mounting horizontally or vertically via two Omega holders

Temperatures

Maximum ambient temperature : 45° C
Maximum housing temperature : 70° C

Distances

Min. distance from flammable surfaces: 0.5 m
Min. distance to lit object: 3 m

Total heat dissipation

max. 1126 BTU/h (calculated)

Protection factor

IP20

Weight

18.08kg (39.9 lbs)

Dimensions (mm)

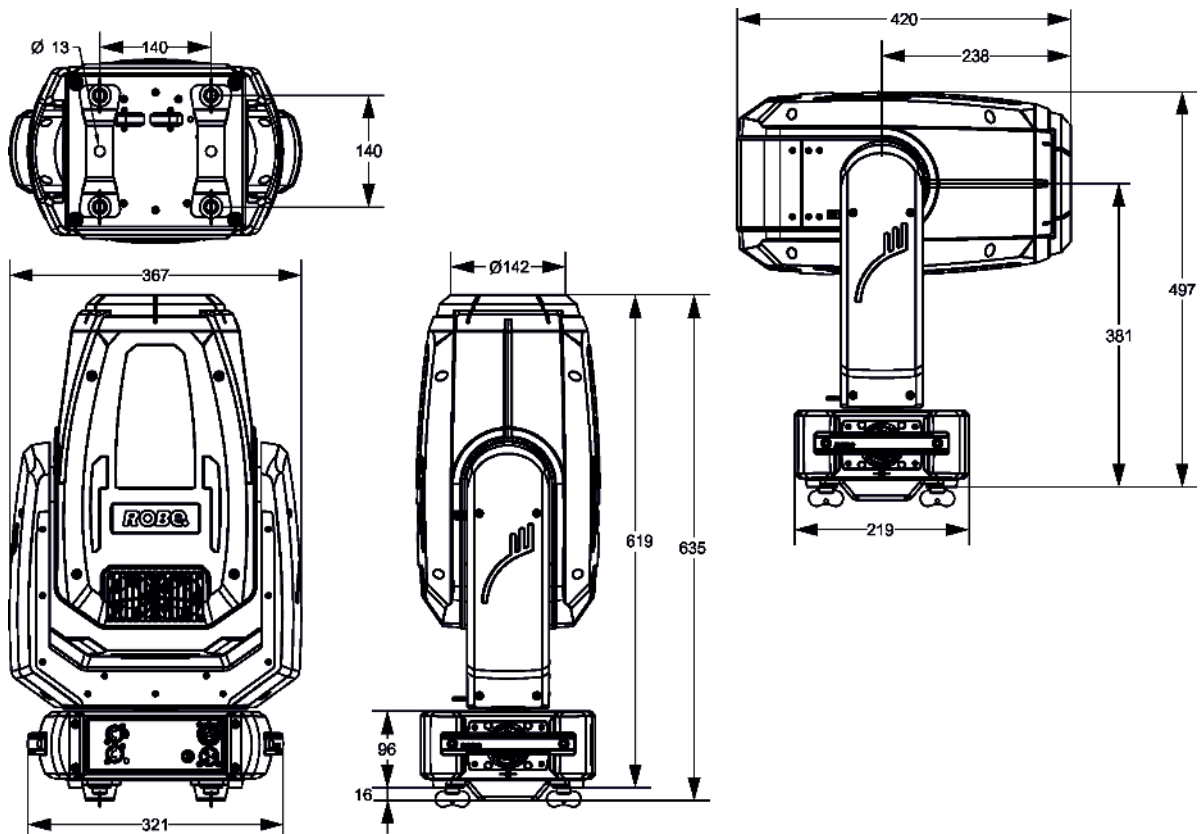

Accessories

1 x Omega adapter CL-regular 2 pcs in box (P/N 10980033)
1 x Power cord including powerCON TRUE1 In connector
1 x User manual

Optional accessories

- (P/N 1305 2405) Mains Cable PowerCon In TRUE1/Schuko, 2m, indoor
- (P/N 1305 2406) Mains Cable PowerCon In TRUE1/US, 2m, indoor
- (P/N 1305 2407) Mains Cable PowerCon In TRUE1/open ended, 2m, indoor
- (P/N 13052445) Mains Cable PowerCon In TRUE1/CEE 16A, 2m, indoor
- (P/N 1305 2439) Daisy Chain PowerCon TRUE1 In/Out, EU, 2m, indoor
- (P/N 1305 2440) Daisy Chain PowerCon TRUE1 In/Out, US, 2m, indoor
- (P/N 13052444) Daisy Chain PowerCon TRUE1 In/Out, EU, 5m, indoor
- (P/N 10980690) Frost 0.5° (exchange) assembled
- (P/N 10980691) Frost 1° (exchange) assembled
- (P/N 10980758) Frost 3,5° (exchange) assembled
- (P/N 10980693) Frost 10° (exchange) assembled
- (P/N 10980694) Frost 20° (exchange) assembled
- (P/N 109806915) Frost 30° (exchange) assembled
- (P/N 10980033) Omega Adaptor CL-regular 2 pcs
- (P/N 17030386) Doughty Trigger Clamp
- (P/N 99011963) Safety wire 36 kg
- (P/N 99030100) Upgrade kit CRMX Universal 260
- (P/N 14080083) TE™ HCF LED Engine for Painte
- (P/N 14080078) TE™ HP LED Engine for Painte
- (P/N 14080099) Painte TE™ 310W TGW White LED Engine
- (P/N 99030449) Upgrade kit EPASS Painte 48V
- (P/N 10981120) Frame Adaptor Painte Profile/Spot
- (P/N 99017007) Module Framing Shutters instead of the Iris module

11. Maintenance and cleaning

DANGER !
***Disconnect from the mains before starting any
maintenance work***

Never use alcohol or solvents for cleaning the front lens and covers of the fixture

It is absolutely essential that the fixture is kept clean and that dust, dirt and smoke-fluid residues must not build up on or within the fixture. Otherwise, the fixture's light output will be significantly reduced. Regular cleaning will not only ensure the maximum light output, but will also allow the fixture to function reliably throughout its life. A soft lint-free cloth moistened with any good glass cleaning fluid is recommended, under no circumstances should alcohol or solvents be used!

Front lens may require weekly cleaning as smoke-fluid tends to building up residues, reducing the light output very quickly. The cooling fans should be cleaned according to the situation (at least annually). The interior of the head and base should be cleaned at least annually using a vacuum-cleaner.

Periodically clean the air filter placed in the fixture base. This air filter is placed under a grille, which is fastened by means of two magnets.

Use a vacuum cleaner, compressed air or you can wash them and put back dry.

After replacing the air filter, reset the elapsed time counter in the tab "Information" (Information--->Air Filters--->Elapsed Time).

Sliding bars of CMY colour mix. system should be lubricated every 6 months. As lubricant we recommend ÄRONIX silicone oil 500 cSt - it is a medium viscosity lubricant, release agent, high temperature oil (from -20°C to +300°C).

More complicated maintenance and service operations are only to be carried out by authorized distributors.

11.1 Replacing the fuse

Before replacing the fuse, unplug mains lead!

1. Remove the fuse holder on the rear panel of the base with a fitting screwdriver from the housing (anti-clockwise).
2. Remove the old fuse from the fuse holder.
3. Install the new fuse in the fuse holder (only the same type and rating).
4. Replace the fuse holder in the housing and fix it.

11.2 Checking plastic parts of the fixture

The plastic parts of the fixture should be checked for damages and beginning cracks at least every two months. If hint of a crack is found on some plastic part, do not use the fixture until the damaged part will be replaced. Cracks or another damages of the plastic parts can be caused by the fixture transportation or manipulation and also aging process may influence plastic materials.

This checking is necessary for both fixed installations and preparing fixtures for renting. Any free moving parts inside of the fixture or any cracked plastic not sitting properly in place need to be immediately replaced.

11.3 Disposing of the product

To preserve the environment please dispose or recycle this product at the end of its life according to the local regulations and codes.

11. ChangeLog

This section summarizes changes in the user manual.

| Version of the manual | Date of issue | Description of changes |
|-----------------------|---------------|--|
| 1.1 | 23/03/2023 | EMC notes added |
| 1.2 | 14/12/2023 | Error messages changed |
| 1.3 | 21/10/2024 | Optional Module Framing Shutters instead of the Iris module added to spec. |

October 21 2024

Copyright © 2022-2024 Robe Lighting - All rights reserved

Specifications are subject to change without notice.

Made in ROBE Lighting s.r.o., Palackého 416, 757 01 Valašské Meziříčí, Czech Republic



12. Appendix

12.1 Changing the LED light source

The Painte Spot allows you to change the LED light source and this way keep a high performance of the fixture.

To change the LED light source.

1. Disconnect the fixture from mains and allow it to cool about 30 minutes.
2. Remove both head covers of the fixture and lock the head in a horizontal position in which you will have access to the LED control PCB (1).
3. Remove the rear cover (3) of the head by unscrewing the four screws M3x8 (2) with star washers.
4. Cut off the cable binder (4) and release the LED source cable (5). Disconnect the cable connector (6) from the LED control PCB (1).
5. Unscrew the four socket cap screws M4x14 (7) with washers and carefully remove the LED module (8) from the head (9).

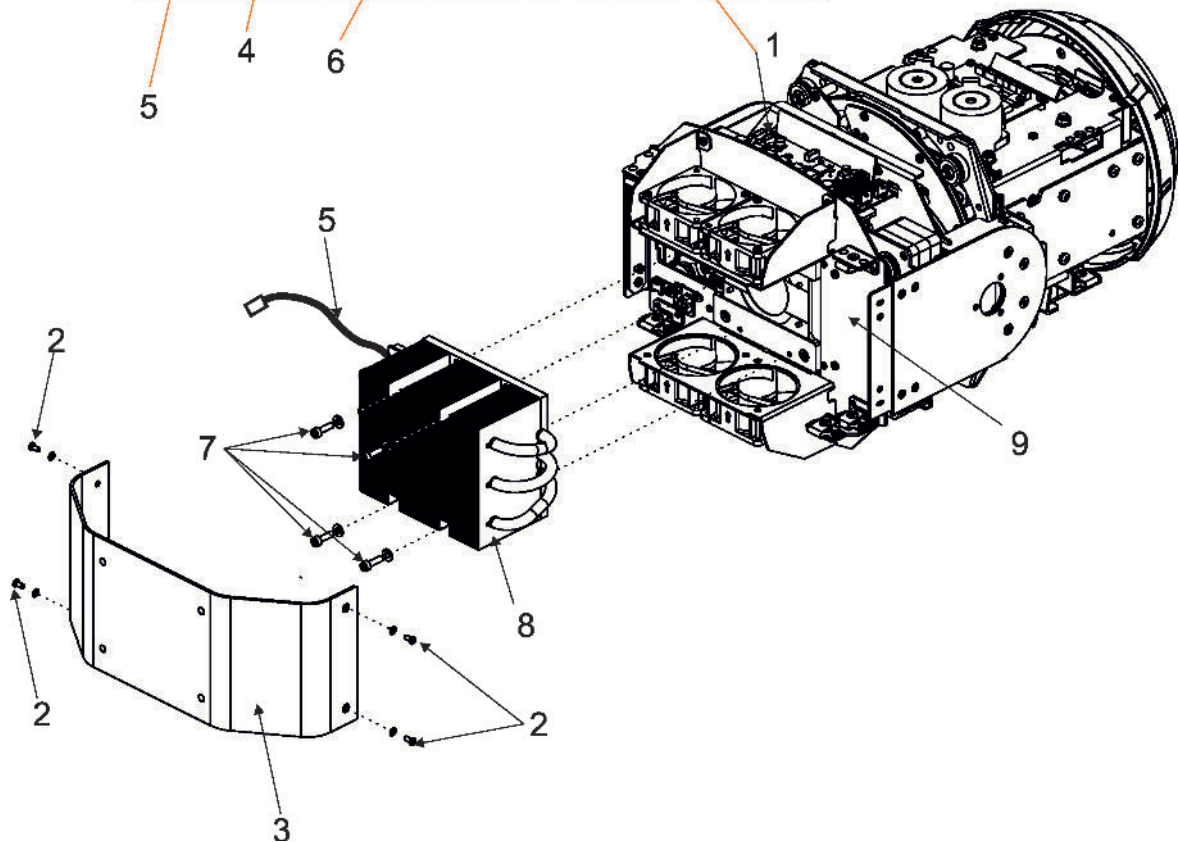
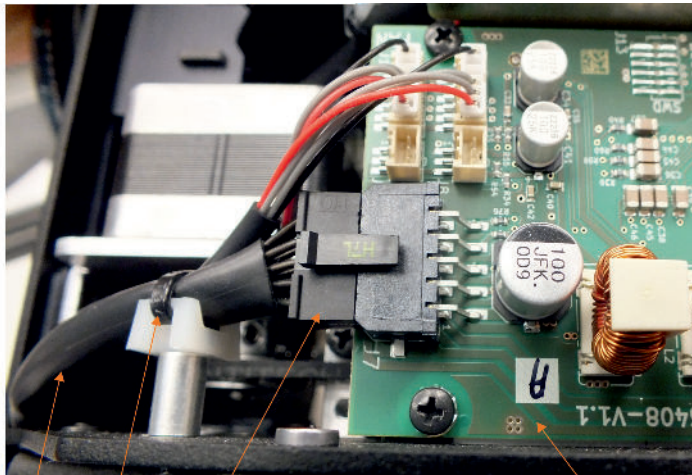

The LED module consists of the LED PCB (A) with LED source cable and the heatsink (B).

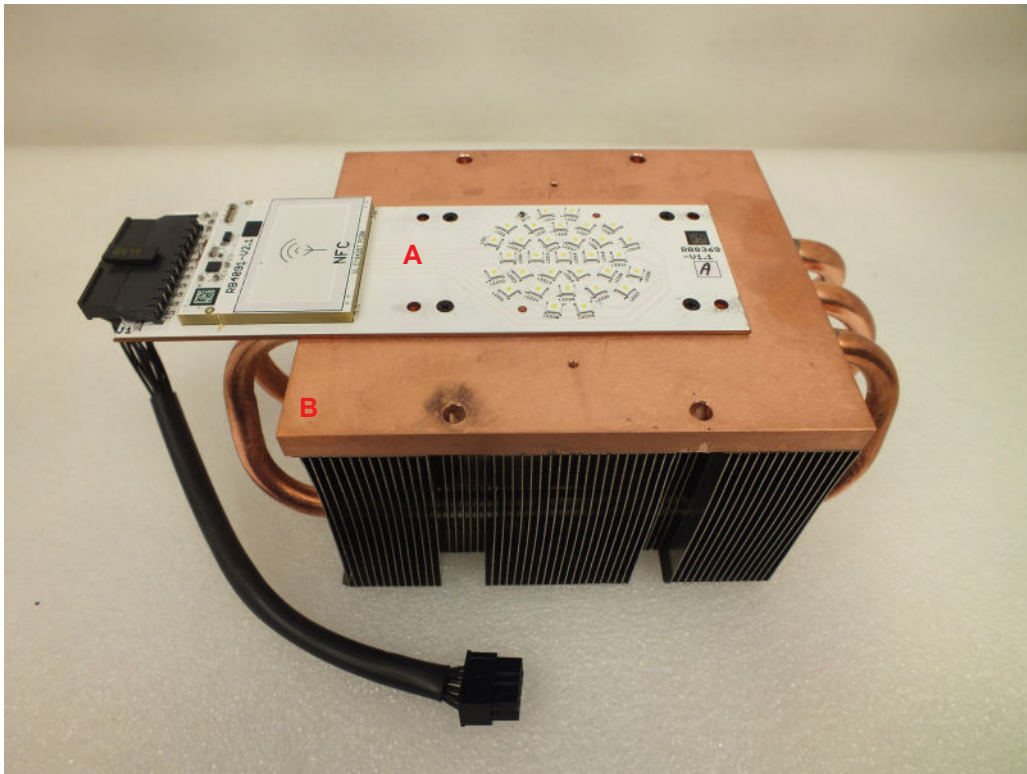

6. Screw the new LED module to the head by means of the he four socket cap screws M4x14 (7) with washers
7. Connect the cable connector (6) to the control PCB. Fasten the cable (5) to the holder by means of the cable binder (4).
8. Screw the rear cover (3) back to the head by means of the the four screws M3x8 (2) with star washers.
- 9 Fasten the head covers back on the head and check their attachment including securing wires.

12.2. Obtaining information about the LED light source by mobile phone

You can read information about the LED light source by means of the mobile application ROBE COM. The LED light source has to be outside of the fixture.

Download and install the application ROBE COM from Google Play (for Android 5.0 and higher) or App Store (for iOS 12.0 and higher) to your mobile phone. Your mobile phone has to support NFC (Near-Field Communication).

After installing the ROBE COM, run the application by touching the icon  .
The following screen will appear:

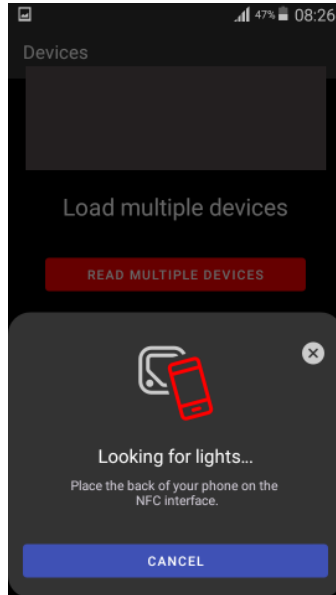

Hold the mobile phone close to the point of the LED PCB which is marked with the symbol NFC.

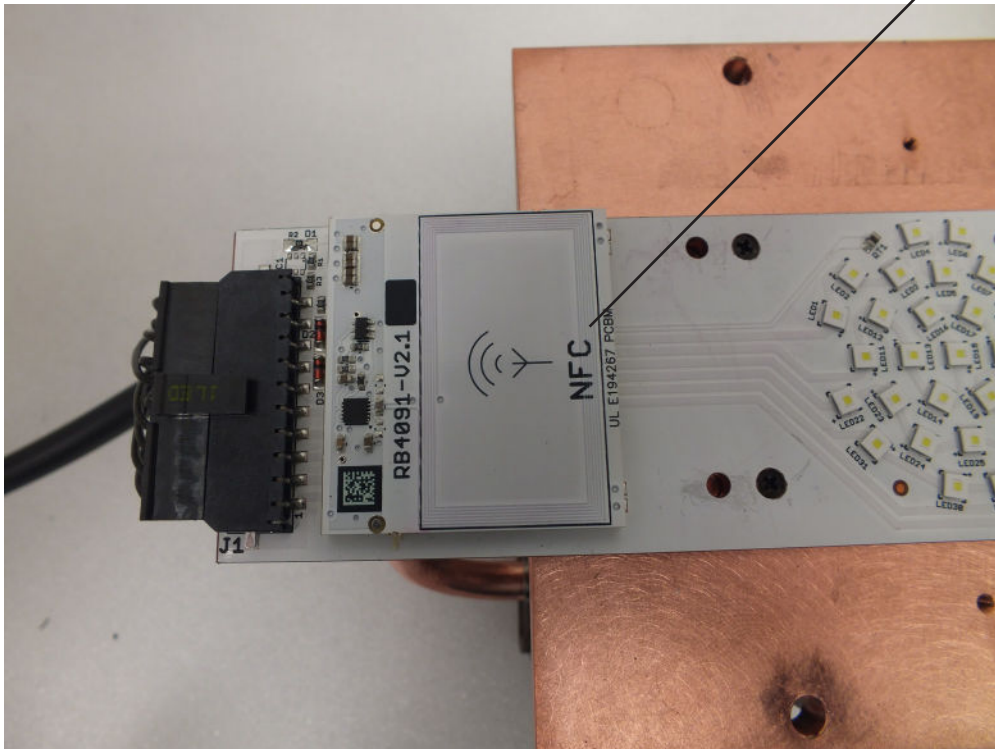

If NFC connection is OK, the following screens will appear.

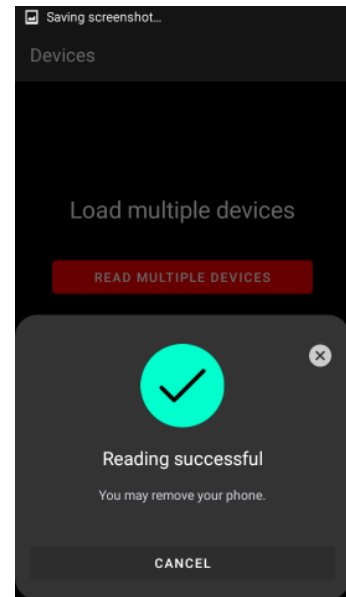
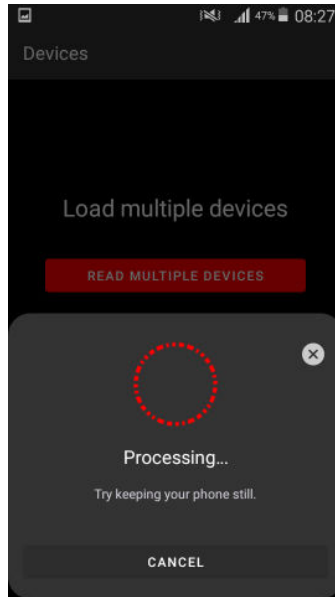
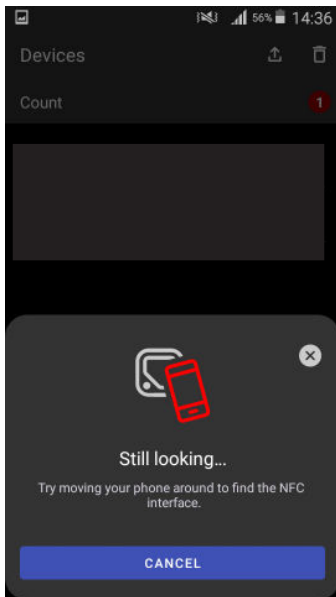

When the following screen will appear, touch the button CANCEL.

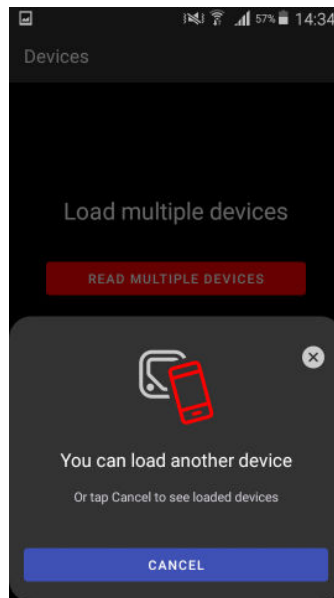

Touch the found LED module ("Robin Cuete LED module") and than touch "LED engine" to read information about found LED module.

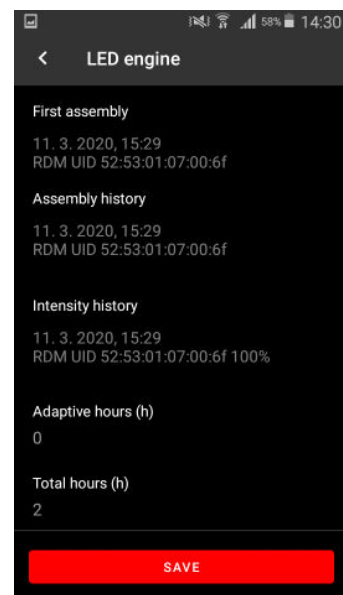
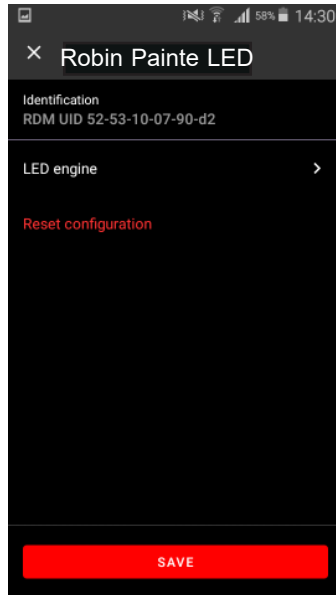
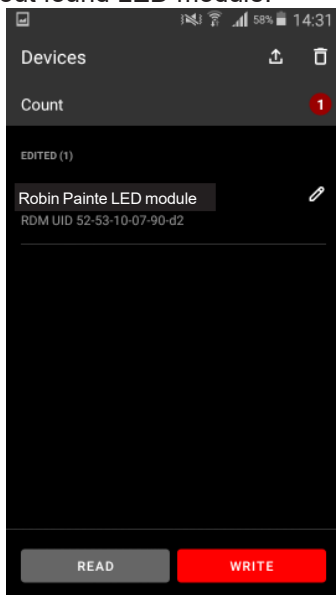

DMX protocol

| Painte® Spot - DMX protocol | | | | | |
|--|----------|---|---|-----------------|--|
| Version 1.0 Standard 16 bit, Mode 2 -enhanced gobo control | | | | | |
| Mode/Total channels | | DMX Value | Function | Type of control | |
| 1/35 | 2/36 | | | | |
| 1 | 1 | 0 - 255 | Pan Pan movement by 540° (128=default) | proportional | |
| 2 | 2 | 0 - 255 | Pan Fine Fine control of pan movement (0=default) | proportional | |
| 3 | 3 | 0 - 255 | Tilt Tilt movement by 270° (128=default) | proportional | |
| 4 | 4 | 0 - 255 | Tilt fine Fine control of tilt movement (0=default) | proportional | |
| 5 | 5 | 0 | Pan/Tilt speed , Pan/Tilt time Standard mode (0=default) | step | |
| | | 1 | Max. Speed Mode | step | |
| | | Pan/Tilt speed mode | | | |
| | | 2 - 255 | Speed from max. to min. | proportional | |
| | | Pan/Tilt time mode | | | |
| | | 2 - 255 | Time from 0.2 s to 25.5 sec. | proportional | |
| 6 | 6 | 0 - 9 | Power/Special functions Reserved (0=default) <i>To activate following functions, stop in DMX value for at least 3 s and shutter must be closed at least 3 sec. („Shutter,Strobe“ channel 33/34 must be at range: 0-31 DMX). Corresponding menu items are temporarily overridden.</i> | | |
| | | 10-14 | DMX input: Wired DMX * | step | |
| | | 15-19 | DMX input: Wireless DMX * | step | |
| | | * function is active only 10 seconds after switching the fixture on | | | |
| | | 20-24 | Graphic display: On | step | |
| | | 25-29 | Graphic display: Off | step | |
| | | 30-31 | Quiet mode: Fans On at blackout | step | |
| | | 32-33 | Quiet mode: Fans Off at blackout | step | |
| | | 34-35 | Dimmer curve: Super Square Law | step | |
| | | 36-39 | Reserved | | |
| | | 40-44 | Pan/Tilt mode: Speed | step | |
| | | 45-49 | Pan/Tilt mode: Time | step | |
| | | 50-54 | Blackout while pan/tilt moving: On | step | |
| | | 55-59 | Blackout while pan/tilt moving: Off | step | |
| | | 60-64 | Blackout while gobo wheel moving: On | step | |
| | | 65-69 | Blackout while gobo wheel moving: Off | step | |
| | | 70-74 | Blackout while colour wheel moving: On | step | |
| | | 75-79 | Blackout while colour wheel moving: Off | step | |
| | | 80-84 | Fans mode: Auto | step | |
| | | 85-89 | Fans mode: High | step | |
| 90-99 | Reserved | | | | |
| | | 100-104 | Focus Tracking: On | step | |
| | | 105-109 | Focus Tracking: Off | step | |
| | | 110-114 | Dimmer curve: Square law | step | |
| | | 115-119 | Dimmer curve: Linear | step | |

DMX protocol

| Mode/Total channels | | DMX Value | Function | Type of control |
|---------------------|----------|-----------|---|-----------------|
| 1/35 | 2/36 | | | |
| | | 120-124 | Parking position: On | step |
| | | 125-129 | Parking position: Off | step |
| | | | <i>To activate following functions, stop in DMX value for at least 3 seconds.</i> | |
| | | 130 - 139 | Total fixture reset (without pan/tilt) | step |
| | | 140 - 149 | Pan and Tilt reset | step |
| | | 150 - 159 | Colour system reset | step |
| | | 160 - 169 | Gobo wheels reset | step |
| | | 170-174 | Pan reset | step |
| | | 175-179 | Tilt reset | step |
| | | 180 - 189 | Zoom/focus/frost/prism reset | step |
| | | 190 - 199 | Iris reset | step |
| | | 200 - 209 | Total fixture reset (including pan/tilt) | step |
| | | 210 - 218 | Reserved | |
| | | | The following three commands define transition from gobo rotation to gobo indexing: | |
| | | 219 - 220 | Gobo indexing: Maximum speed and shortcut | step |
| | | 221 - 222 | Gobo indexing: Follow speed and direction | step |
| | | 223 - 224 | Gobo indexing: Maximum speed and follow direction | step |
| | | | The following RoboSpot related commands are only applicable when the RoboSpot is connected: | |
| | | 225 - 229 | RoboSpot enabled | step |
| | | 230 - 234 | RoboSpot disabled - except handle faders and pan/tilt | step |
| | | 235 - 239 | RoboSpot fully disabled | step |
| | | 240 | Disabled "Quiet mode" | step |
| | | 241 - 255 | Quiet mode - fan noise control from min. to max. | proportional |
| 7 | 7 | | LED frequency selection | |
| | | | Factory display menu setting: 600Hz | |
| | | | <i>Select PWM output frequency of LEDs. Selected PWM frequency can be fine adjusted in 127 steps up/down around selected PWM frequency on the channel below. Corresponding menu item is temporarily overridden.</i> | |
| | | 0-4 | PWM frequency from Display menu (fixture utilizes PWM frequency set in the display menu item Frequency Setup). | step |
| | | 5-9 | 300 Hz | step |
| | | 10-14 | 600 Hz (10=default) | step |
| | | 15-19 | 1200 Hz | step |
| | | 20-24 | 2400 Hz | step |
| | | 25-29 | High | step |
| | | 30-255 | Reserved (fixture utilizes PWM frequency set in the display menu item Frequency Setup). | |
| 8 | 8 | | LED frequency fine adjusting | |
| | | | Factory display menu setting: 600Hz | |
| | | | <i>Select desired PWM output frequency of LEDs on the channel above.</i> | |
| | | 0-1 | Selected LED Frequency | step |
| | | 2 | LED Frequency (step -126) | step |
| | | 3 | LED Frequency (step -125) | step |
| | | 4 | LED Frequency (step -124) | step |
| | | : | | |

DMX protocol

| Mode/Total channels | | DMX Value | Function | Type of control |
|---------------------|-----------|-----------|---|-----------------|
| 1/35 | 2/36 | | | |
| | | 125 | LED Frequency (step -3) | step |
| | | 126 | LED Frequency (step -2) | step |
| | | 127 | LED Frequency (step -1) | step |
| | | 128 | Selected LED Frequency (128=default) | step |
| | | 129 | LED Frequency (step +1) | step |
| | | 130 | LED Frequency (step +2) | step |
| | | 131 | LED Frequency (step +3) | step |
| | | : | | |
| | | 252 | LED Frequency (step +124) | step |
| | | 253 | LED Frequency (step +125) | step |
| | | 254 | LED Frequency (step +126) | step |
| | | 255 | Selected LED Frequency | step |
| 9 | 9 | | Max. light intensity indication and setting | |
| | | 0-10 | No function (0=default) | |
| | | 11-20 | Indication of drop of max. light intensity | step |
| | | | <i>A drop of max. light intensity of the fixture (compared to its original intensity) is indicated by a corresponding colour output: 0-5%, (WHITE /new LED module/) 6-10% (RED) 11-15% (GREEN) 16-20% (BLUE) 21-25% (CYAN) 26-30% (MAGENTA) 31-35% (YELLOW) 36-40% (ORANGE) Pan/tilt is set at 128 DMX (50%), Dimmer is open at 255 DMX (100%).</i> | |
| | | | <i>To set a drop of max. light intensity (compared to original light intensity), stay at DMX value for at least 3 sec. and shutter must be closed at least 3 sec. (Channel „Shutter/ Strobe“ 42/43 must be at range: 0-31 DMX). Corresponding menu items are permanently overwritten.</i> | |
| | | 21-30 | Set drop by 6-10% (RED) | step |
| | | 31-40 | Set drop by 11-15% (GREEN) | step |
| | | 41-50 | Drop by 16-20% (BLUE) | step |
| | | 51-60 | Set drop by 21-25% (CYAN) | step |
| | | 61-70 | Set drop by 26-30% (MAGENTA) | step |
| | | 71-80 | Set drop by 31-35% (YELLOW) | step |
| | | 81-90 | Set drop by 36-40% (ORANGE) | step |
| | | 91-100 | Original intensity (WHITE) | step |
| | | 101-255 | Reserved | |
| 10 | 10 | | Colour wheel | |
| | | | Continual positioning | |
| | | 0 | Open/white | proportional |
| | | 12 | Deep red | proportional |
| | | 25 | Deep blue | proportional |
| | | 39 | Light green | proportional |
| | | 51 | Lavender | proportional |

DMX protocol

| Mode/Total channels | | DMX Value | Function | Type of control |
|---------------------|-----------|-----------|--|-----------------|
| 1/35 | 2/36 | | | |
| | | 64 | Orange | proportional |
| | | 77 | Multicolor | proportional |
| | | 90 | Filter CRI 90 | proportional |
| | | 103 | CTO 3200K | proportional |
| | | 115 | Congo blue | proportional |
| | | 128-129 | White | step |
| | | | Positioning | |
| | | 130-136 | Deep red | step |
| | | 137-142 | Deep blue | step |
| | | 143-149 | Light green | step |
| | | 150-155 | Lavender | step |
| | | 156-162 | Orange | step |
| | | 163-168 | Multicolor | step |
| | | 169-175 | Filter CRI 90 | step |
| | | 176-182 | CTO 3200K | step |
| | | 183-189 | Congo blue | step |
| | | 190 - 215 | Forwards rainbow effect from fast to slow | proportional |
| | | 216 - 217 | No rotation | step |
| | | 218 - 243 | Backwards rainbow effect from slow to fast | proportional |
| | | 244 - 249 | Random colour selection by audio control | step |
| | | | (Set microphone sensitivity in menu „Personality“) | |
| | | 250 - 255 | Auto random colour selection from fast to slow | proportional |
| 11 | 11 | | Colour wheel - fine positioning | |
| | | 0 - 255 | Fine positioning (0=default) | proportional |
| 12 | 12 | | Cyan | |
| | | 0 - 255 | Cyan from min. saturation --> full cyan (0=default) | proportional |
| 13 | 13 | | Magenta | |
| | | 0 - 255 | Magenta from min. saturation --> full magenta (0=default) | proportional |
| 14 | 14 | | Yellow | |
| | | 0 - 255 | Yellow from min. saturation --> full yellow (0=default) | proportional |
| 15 | 15 | | Virtual CTO | |
| | | 0-255 | Colour temperature change from 6700K --> 2700K (0=default) | proportional |
| 16 | 16 | | Green correction | |
| | | 0 | Uncorrected white | step |
| | | 1-127 | Minus green --> uncorrected white | proportional |
| | | 128 | Uncorrected white (128=default) | step |
| | | 129-255 | Uncorrected white --> Plus green | proportional |
| 17 | 17 | | Virtual colour wheel | |
| | | | <i>See table "Colours on Virtual Colour Wheel" to find components of each colour</i> | |
| | | | <i>The following channels are disabled: 9-16</i> | |
| | | 0 | No function (0=default) | step |
| | | 1-2 | Filter 4 (Medium Bastard Amber) | step |
| | | 3-4 | Filter 10 (Medium Yellow) | step |
| | | 5-6 | Filter 19 (Fire) | step |
| | | 7-8 | Filter 26 (Bright Red) | step |
| | | 9-10 | Filter 58 (Lavender) | step |
| | | 11-12 | Filter 68 (Sky Blue) | step |

DMX protocol

| Mode/Total channels | | DMX Value | Function | Type of control |
|---------------------|------|-----------|--------------------------------|-----------------|
| 1/35 | 2/36 | | | |
| | | 13-14 | Filter 71 (Tokyo Blue) | step |
| | | 15-16 | Filter 79 (Just Blue) | step |
| | | 17-18 | Filter 88 (Lime Green) | step |
| | | 19-20 | Filter 90 (Dark Yellow Green) | step |
| | | 21-22 | Filter 100 (Spring Yellow) | step |
| | | 23-24 | Filter 101 (Yellow) | step |
| | | 25-26 | Filter 102 (Light Amber) | step |
| | | 27-28 | Filter 103 (Straw) | step |
| | | 29-30 | Filter 104 (Deep Amber) | step |
| | | 31-32 | Filter 105 (Orange) | step |
| | | 33-34 | Filter 106 (Primary Red) | step |
| | | 35-36 | Filter 111 (Dark Pink) | step |
| | | 37-38 | Filter 115 (Peacock Blue) | step |
| | | 39-40 | Filter 116 (Medium Blue-Green) | step |
| | | 41-42 | Filter 117 (Steel Blue) | step |
| | | 43-44 | Filter 118 (Light Blue) | step |
| | | 45-46 | Filter 119 (Dark Blue) | step |
| | | 47-48 | Filter 120 (Deep Blue) | step |
| | | 49-50 | Filter 121 (Filter Green) | step |
| | | 51-52 | Filter 128 (Bright Pink) | step |
| | | 53-54 | Filter 131 (Marine Blue) | step |
| | | 55-56 | Filter 132 (Medium Blue) | step |
| | | 57-58 | Filter 134 (Golden Amber) | step |
| | | 59-60 | Filter 135 (Deep Golden Amber) | step |
| | | 61-62 | Filter 136 (Pale Lavender) | step |
| | | 63-64 | Filter 137 (Special Lavender) | step |
| | | 65-66 | Filter 138 (Pale Green) | step |
| | | 67-68 | Filter 139 (Primary Green) | step |
| | | 69-70 | Filter 141 (Bright Blue) | step |
| | | 71-72 | Filter 147 (Apricot) | step |
| | | 73-74 | Filter 148 (Bright Rose) | step |
| | | 75-76 | Filter 152 (Pale Gold) | step |
| | | 77-78 | Filter 154 (Pale Rose) | step |
| | | 79-80 | Filter 157 (Pink) | step |
| | | 81-82 | Filter 158 (Deep Orange) | step |
| | | 83-84 | Filter 162 (Bastard Amber) | step |
| | | 85-86 | Filter 164 (Flame Red) | step |
| | | 87-88 | Filter 165 (Daylight Blue) | step |
| | | 89-90 | Filter 169 (Lilac Tint) | step |
| | | 91-92 | Filter 170 (Deep Lavender) | step |
| | | 93-94 | Filter 172 (Lagoon Blue) | step |
| | | 95-96 | Filter 179 (Chrome Orange) | step |
| | | 97-98 | Filter 180 (Dark Lavender) | step |
| | | 99-100 | Filter 181 (Congo Blue) | step |
| | | 101-102 | Filter 197 (Alice Blue) | step |
| | | 103-104 | Filter 201 (Full C.T. Blue) | step |
| | | 105-106 | Filter 202 (Half C.T. Blue) | step |
| | | 107-108 | Filter 203 (Quarter C.T. Blue) | step |

DMX protocol

| Mode/Total channels | | DMX Value | Function | Type of control |
|---------------------|-----------|-----------|--|-----------------|
| 1/35 | 2/36 | | | |
| | | 109-110 | Filter 204 (Full C.T. Orange) | step |
| | | 111-112 | Filter 205 (Half C.T. Orange) | step |
| | | 113-114 | Filter 206 (Quarter C.T. Orange) | step |
| | | 115-116 | Filter 247 (Filter Minus Green) | step |
| | | 117-118 | Filter 248 (Half Minus Green) | step |
| | | 119-120 | Filter 281 (Three Quarter C.T. Blue) | step |
| | | 121-122 | Filter 285 (Three Quarter C.T. Orange) | step |
| | | 123-124 | Filter 352 (Glacier Blue) | step |
| | | 125-126 | Filter 353 (Lighter Blue) | step |
| | | 127-128 | Filter 715 (Cabana Blue) | step |
| | | 129-130 | Filter 778 (Millennium Gold) | step |
| | | 131-132 | Filter 793 (Vanity Fair) | step |
| | | 133-255 | Reserved | |
| 18 | 18 | | CMY and Colour wheel time | |
| | | 0 | Function is off (0=default) | step |
| | | 1 - 255 | Time of CMY and Colour wheel movement (0.1sec-->25.5sec.) | proportional |
| 19 | 19 | | Framing shutters/Zoom/Focus/Frost/Iris/Prism time | |
| | | 0 | Function is off (0=default) | step |
| | | 1 - 255 | Time of framing shutters, zoom, focus, iris and frost movement (0.1 sec-->25.5 sec.) | proportional |
| | | 1-50 | Time of prism movement (0.1 sec-->5 sec.) | proportional |
| 20 | 20 | | Static gobo wheel | |
| | | 0-8 | Open/hole | step |
| | | | <u>Positioning</u> | |
| | | 9-17 | Gobo 1 | step |
| | | 18-26 | Gobo 2 | step |
| | | 27-35 | Gobo 3 | step |
| | | 36-44 | Gobo 4 | step |
| | | 45-53 | Gobo 5 | step |
| | | 54-62 | Gobo 6 | step |
| | | 63-71 | Gobo 7 | step |
| | | 72-80 | Gobo 8 | step |
| | | 81-91 | Gobo 9 | step |
| | | | <u>Shaking gobos from slow to fast</u> | |
| | | 92-103 | Gobo 1 | proportional |
| | | 104-115 | Gobo 2 | proportional |
| | | 116-127 | Gobo 3 | proportional |
| | | 128-139 | Gobo 4 | proportional |
| | | 140-151 | Gobo 5 | proportional |
| | | 152-163 | Gobo 6 | proportional |
| | | 164-175 | Gobo 7 | proportional |
| | | 176-187 | Gobo 8 | proportional |
| | | 188-199 | Gobo 9 | proportional |
| | | 200-201 | Open/hole | step |
| | | 202 - 222 | Forwards gobo wheel rotation from fast to slow | proportional |
| | | 223 - 243 | Backwards gobo wheel rotation from slow to fast | proportional |
| | | 244 - 249 | Random gobo selection by audio control | step |
| | | | (Set microphone sensitivity in menu „Personality“) | |

DMX protocol

| Mode/Total channels | | DMX Value | Function | Type of control |
|---------------------|-----------|-----------|--|-----------------|
| 1/35 | 2/36 | | | |
| | | 250 - 255 | <i>Auto random gobo selection from fast to slow</i> | proportional |
| 21 | * | | Rotating gobo wheel | |
| | | | <i>Index - set indexing on channel 22</i> | |
| | | 0-9 | Open/Hole (default) | step |
| | | 10-13 | Gobo 1 | step |
| | | 14-17 | Gobo 2 | step |
| | | 18-21 | Gobo 3 | step |
| | | 22-25 | Gobo 4 | step |
| | | 26-29 | Gobo 5 | step |
| | | 30-33 | Gobo 6 | step |
| | | 34-37 | Gobo 7 | step |
| | | 38-41 | Gobo 8 | step |
| | | | <i>Rotation - set rotation on channel 22</i> | |
| | | 42-45 | Gobo 1 | step |
| | | 46-49 | Gobo 2 | step |
| | | 50-53 | Gobo 3 | step |
| | | 54-57 | Gobo 4 | step |
| | | 58-61 | Gobo 5 | step |
| | | 62-65 | Gobo 6 | step |
| | | 66-69 | Gobo 7 | step |
| | | 70-73 | Gobo 8 | step |
| | | | <i>Shaking gobos from slow to fast</i> | |
| | | | <i>Index - set indexing on channel 22</i> | |
| | | 74-81 | Gobo 1 | proportional |
| | | 82-89 | Gobo 2 | proportional |
| | | 90-97 | Gobo 3 | proportional |
| | | 98-105 | Gobo 4 | proportional |
| | | 106-113 | Gobo 5 | proportional |
| | | 114-121 | Gobo 6 | proportional |
| | | 122-129 | Gobo 7 | proportional |
| | | 130-137 | Gobo 8 | proportional |
| | | | <i>Shaking gobos from slow to fast</i> | |
| | | | <i>Rotation - set rotation on channel 22</i> | |
| | | 138-145 | Gobo 1 | proportional |
| | | 146-153 | Gobo 2 | proportional |
| | | 154-161 | Gobo 3 | proportional |
| | | 162-169 | Gobo 4 | proportional |
| | | 170-177 | Gobo 5 | proportional |
| | | 178-185 | Gobo 6 | proportional |
| | | 186-192 | Gobo 7 | proportional |
| | | 193-199 | Gobo 8 | proportional |
| | | 200 - 201 | Open/hole | step |
| | | 202 - 222 | Forwards gobo wheel rotation from fast to slow | proportional |
| | | 223 - 243 | Backwards gobo wheel rotation from slow to fast | proportional |
| | | 244 - 249 | Random gobo selection by audio control (Set microphone sensitivity in menu „Personality“) | step |
| | | 250 - 255 | Auto random gobo selection from fast to slow | proportional |
| * | 21 | | Rotating gobo wheel | |

DMX protocol

| Mode/Total channels | | DMX Value | Function | Type of control |
|---------------------|------|-----------|--|-----------------|
| 1/35 | 2/36 | | | |
| | | | Index - set indexing on channel 23 | |
| | | 0-9 | Open/Hole (default) | step |
| | | 10-13 | Gobo 1 | step |
| | | 14-17 | Gobo 2 | step |
| | | 18-21 | Gobo 3 | step |
| | | 22-25 | Gobo 4 | step |
| | | 26-29 | Gobo 5 | step |
| | | 30-33 | Gobo 6 | step |
| | | 34-37 | Gobo 7 | step |
| | | 38-41 | Gobo 8 | step |
| | | | Rotation - set rotation on channel 23 | |
| | | 42-45 | Gobo 1 | step |
| | | 46-49 | Gobo 2 | step |
| | | 50-53 | Gobo 3 | step |
| | | 54-57 | Gobo 4 | step |
| | | 58-61 | Gobo 5 | step |
| | | 62-65 | Gobo 6 | step |
| | | 66-69 | Gobo 7 | step |
| | | 70-73 | Gobo 8 | step |
| | | | Continual positioning | |
| | | | Index - set indexing on channel 23 | |
| | | 74 | Open/hole | proportional |
| | | 81 | Gobo 1 | proportional |
| | | 88 | Gobo 2 | proportional |
| | | 95 | Gobo 3 | proportional |
| | | 102 | Gobo 4 | proportional |
| | | 109 | Gobo 5 | proportional |
| | | 116 | Gobo 6 | proportional |
| | | 123 | Gobo 7 | proportional |
| | | 130 | Gobo 8 | proportional |
| | | 137 | Open/hole | proportional |
| | | | Continual positioning | |
| | | | Rotation - set rotation on channel 23 | |
| | | 138 | Open/hole | proportional |
| | | 145 | Gobo 1 | proportional |
| | | 152 | Gobo 2 | proportional |
| | | 159 | Gobo 3 | proportional |
| | | 166 | Gobo 4 | proportional |
| | | 173 | Gobo 5 | proportional |
| | | 180 | Gobo 6 | proportional |
| | | 187 | Gobo 7 | proportional |
| | | 194 | Gobo 8 | proportional |
| | | 201 | Open/hole | proportional |
| | | 202 - 222 | Forwards gobo wheel rotation from fast to slow | proportional |
| | | 223 - 243 | Backwards gobo wheel rotation from slow to fast | proportional |
| | | 244 - 249 | Random gobo selection by audio control (Set microphone sensitivity in menu „Personality“) | step |
| | | 250 - 255 | Auto random gobo selection from fast to slow | proportional |

DMX protocol

| Mode/Total channels | | DMX Value | Function | Type of control |
|---------------------|------|-----------|--|-----------------|
| 1/35 | 2/36 | | | |
| * | 22 | | Rotating gobo wheel - fine positioning | |
| | | 0 - 255 | Fine positioning (0=default) | proportional |
| 22 | 23 | | Rot. Gobo indexing/rotation | |
| | | | Gobo indexing - set position on channel 21 | |
| | | 0 - 255 | Gobo indexing (128=default) | proportional |
| | | | Gobo rotation - set position on channel 21 | |
| | | 0 | No rotation | step |
| | | 1 - 127 | Forwards gobo rotation from fast to slow | proportional |
| | | 128 | No rotation (128=default) | step |
| | | 129 - 255 | Backwards gobo rotation from slow to fast | proportional |
| 23 | 24 | | Rot. Gobo indexing/rotation - fine | |
| | | 0-255 | Fine indexing/rotation (0=default) | proportional |
| 24 | 25 | | Prism | |
| | | 0 - 19 | Open position/hole (0=default) | step |
| | | 20 - 73 | Prism indexing | step |
| | | 74-127 | Prism rotation | step |
| | | | Prism/gobo macros | |
| | | | <i>The following channels are blocked: Rotating gobo wheel, Rot. Gobo indexing and rotation, Rot. Gobo wheel fine rotation</i> | |
| | | 128 - 135 | Macro 1 | step |
| | | 136 - 143 | Macro 2 | step |
| | | 144 - 151 | Macro 3 | step |
| | | 152 - 159 | Macro 4 | step |
| | | 160 - 167 | Macro 5 | step |
| | | 168 - 175 | Macro 6 | step |
| | | 176 - 183 | Macro 7 | step |
| | | 184 - 191 | Macro 8 | step |
| | | 192 - 199 | Macro 9 | step |
| | | 200 - 207 | Macro 10 | step |
| | | 208 - 215 | Macro 11 | step |
| | | 216 - 223 | Macro 12 | step |
| | | 224 - 231 | Macro 13 | step |
| | | 232 - 239 | Macro 14 | step |
| | | 240 - 247 | Macro 15 | step |
| | | 248 - 255 | Macro 16 | step |
| 25 | 26 | | Prism indexing/rotation | |
| | | | Prism indexing - set position on channel 24/25 | |
| | | 0 - 255 | Prism 1 indexing | proportional |
| | | | Prism rotation - set position on channel 24/25 | |
| | | 0 | No rotation | step |
| | | 1 - 127 | Forwards prism rotation from fast to slow | proportional |
| | | 128 | No rotation (128=default) | step |
| | | 129-255 | Backwards prism rotation from slow to fast | proportional |
| 26 | 27 | | Frost | |
| | | 0 | Open (0=default) | step |
| | | 1 - 179 | Frost from 0% to 100% | proportional |
| | | 180 - 189 | 100% frost | step |
| | | 190 - 211 | Pulse closing from slow to fast | proportional |

DMX protocol

| Mode/Total channels | | DMX Value | Function | Type of control |
|--|-----------|-----------|--|-----------------|
| 1/35 | 2/36 | | | |
| | | 212 - 233 | Pulse opening from fast to slow | proportional |
| | | 234 - 255 | Ramping from fast to slow | proportional |
| 27 | 28 | | Iris | |
| | | 0 | Open (0=default) | step |
| | | 1 - 179 | From max. diameter to min. diameter | proportional |
| | | 180 - 191 | Closed | step |
| | | | Pulse effects with Iris blackout | |
| | | 192 - 219 | Pulse opening from slow to fast | proportional |
| | | 220 - 247 | Pulse closing from fast to slow | proportional |
| | | 248 - 249 | Random pulse opening (fast) | step |
| | | 250 - 251 | Random pulse opening (slow) | step |
| | | 252 - 253 | Random pulse closing (fast) | step |
| | | 254 - 255 | Random pulse closing (slow) | step |
| 28 | 29 | | Iris - fine | |
| | | 0 - 255 | Fine iris movement (0=default) | proportional |
| 29 | 30 | | Zoom | |
| | | 0 - 255 | Zoom from max. to min. beam angle (128=default) | proportional |
| 30 | 31 | | Zoom - fine | |
| | | 0-255 | Fine zooming (0=default) | proportional |
| 31 | 32 | | Focus | |
| | | 0 - 255 | Continuous adjustment from far to near (128=default) | proportional |
| 32 | 33 | | Focus - fine | |
| | | 0- 255 | Fine focusing (0=default) | proportional |
| 33 | 34 | | Shutter/ strobe | |
| | | 0 - 31 | Shutter closed | step |
| | | 32 - 63 | Shutter open (32=default) | step |
| | | 64 - 95 | Strobe-effect from slow to fast | proportional |
| | | 96 - 127 | Shutter open | step |
| | | 128 - 143 | Opening pulse in sequences from slow to fast | proportional |
| | | 144 - 159 | Closing pulse in sequences from fast to slow | proportional |
| | | 160 - 191 | Shutter open | proportional |
| | | 192 - 223 | Random strobe-effect from slow to fast | proportional |
| | | 224 - 255 | Shutter open | step |
| 34 | 35 | | Dimmer intensity | |
| | | 0 - 255 | Dimmer intensity from 0% to 100% (0=default) | proportional |
| 35 | 36 | | Dimmer intensity - fine | |
| | | 0 - 255 | Fine dimming (0=default) | proportional |
| Copyright © 2021-2023 Robe Lighting s.r.o. - All rights reserved | | | | |
| All Specifications subject to change without notice | | | | |

| Robin Painte®/Painte® Spot - colours on Virtual Colour Wheel | | | | |
|---|-------------------|----------------------|---------------------|---------------------------|
| Colour name | Cyan (DMX) | Magenta (DMX) | Yellow (DMX) | Colour Wheel (DMX) |
| Filter 4 (Medium Bastard Amber) | 0 | 165 | 180 | 0 |
| Filter 10 (Medium Yellow) | 0 | 149 | 228 | 0 |
| Filter 19 (Fire) | 0 | 247 | 255 | 0 |
| Filter 24 (Scarlet) | 0 | 0 | 0 | 134 |
| Filter 58 (Lavender) | 0 | 197 | 97 | 0 |
| Filter 68 (Sky Blue) | 169 | 0 | 0 | 154 |
| Filter 71 (Tokyo Blue) | 0 | 0 | 0 | 142 |
| Filter 79 (Just Blue) | 201 | 172 | 0 | 0 |
| Filter 88 (Lime Green) | 127 | 0 | 214 | 0 |
| Filter 90 (Dark Yellow Green) | 230 | 0 | 224 | 0 |
| Filter 100 (Spring Yellow) | 0 | 117 | 223 | 0 |
| Filter 101 (Yellow) | 0 | 153 | 223 | 0 |
| Filter 102 (Light Amber) | 0 | 151 | 192 | 0 |
| Filter 103 (Straw) | 0 | 135 | 185 | 0 |
| Filter 104 (Deep Amber) | 0 | 172 | 233 | 0 |
| Filter 105 (Orange) | 0 | 195 | 242 | 0 |
| Filter 781 (Terry Red) | 0 | 248 | 0 | 161 |
| Filter 111 (Dark Pink) | 0 | 197 | 189 | 0 |
| Filter 115 (Peacock Blue) | 252 | 0 | 181 | 0 |
| Filter 505 (Sally Green) | 251 | 0 | 189 | 0 |
| Filter 117 (Steel Blue) | 177 | 0 | 146 | 0 |
| Filter 118 (Light Blue) | 235 | 0 | 157 | 0 |
| Filter 724 (Ocean Blue) | 255 | 58 | 0 | 0 |
| Filter 725 (Old Steel Blue) | 255 | 115 | 0 | 0 |
| Filter 121 (Filter Green) | 192 | 0 | 255 | 0 |
| Filter 128 (Bright Pink) | 0 | 231 | 177 | 0 |
| Filter 131 (Marine Blue) | 219 | 0 | 127 | 0 |
| Filter 132 (Medium Blue) | 255 | 0 | 57 | 0 |
| Filter 134 (Golden Amber) | 0 | 191 | 255 | 0 |
| Filter 135 (Deep Golden Amber) | 0 | 222 | 255 | 0 |
| Filter 136 (Pale Lavender) | 0 | 184 | 121 | 0 |
| Filter 137 (Special Lavender) | 0 | 141 | 110 | 0 |
| Filter 138 (Pale Green) | 115 | 0 | 182 | 0 |
| Filter 139 (Primary Green) | 243 | 0 | 236 | 0 |
| Filter 141 (Bright Blue) | 255 | 0 | 114 | 0 |
| Filter 147 (Apricot) | 0 | 177 | 222 | 0 |
| Filter 148 (Bright Rose) | 0 | 220 | 203 | 0 |
| Filter 152 (Pale Gold) | 0 | 173 | 189 | 0 |
| Filter 154 (Pale Rose) | 0 | 170 | 173 | 0 |
| Filter 157 (Pink) | 0 | 214 | 212 | 0 |
| Filter 158 (Deep Orange) | 0 | 216 | 254 | 0 |
| Filter 162 (Bastard Amber) | 0 | 150 | 183 | 0 |
| Filter 164 (Flame Red) | 0 | 255 | 255 | 0 |
| Filter 165 (Daylight Blue) | 217 | 0 | 12 | 0 |
| Filter 169 (Lilac Tint) | 0 | 183 | 143 | 0 |
| Filter 170 (Deep Lavender) | 38 | 183 | 104 | 0 |

| Colour name | Cyan (DMX) | Magenta (DMX) | Yellow (DMX) | Colour Wheel (DMX) |
|--|---------------|------------------|-----------------|--------------------------|
| Filter 172 (Lagoon Blue) | 234 | 0 | 121 | 0 |
| Filter 179 (Chrome Orange) | 0 | 177 | 248 | 0 |
| Filter 180 (Dark Lavender) | 179 | 174 | 0 | 0 |
| Filter 181 (Congo Blue) | 189 | 207 | 0 | 0 |
| Filter 197 (Alice Blue) | 255 | 140 | 0 | 0 |
| Filter 201 (Full C.T. Blue) | 179 | 0 | 99 | 0 |
| Filter 202 (Half C.T. Blue) | 168 | 0 | 81 | 0 |
| Filter 203 (Quarter C.T. Blue) | 151 | 0 | 136 | 0 |
| Filter 204 (Full C.T. Orange) | 0 | 186 | 243 | 0 |
| Filter 205 (Half C.T. Orange) | 0 | 160 | 193 | 0 |
| Filter 206 (Quarter C.T. Orange) | 0 | 155 | 157 | 0 |
| Filter 247 (Filter Minus Green) | 0 | 176 | 123 | 0 |
| Filter 248 (Half Minus Green) | 0 | 114 | 111 | 0 |
| Filter 281 (Three Quarter C.T. Blue) | 179 | 0 | 117 | 0 |
| Filter 285 (Three Quarter C.T. Orange) | 0 | 166 | 232 | 0 |
| Filter 352 (Glacier Blue) | 221 | 0 | 98 | 0 |
| Filter 353 (Lighter Blue) | 237 | 0 | 140 | 0 |
| Filter 715 (Cabana Blue) | 255 | 120 | 0 | 0 |
| Filter 778 (Millennium Gold) | 0 | 210 | 255 | 0 |
| Filter 328 (Follies Pink) | 0 | 231 | 159 | 0 |
| Robin Painte®/Painte® Spot - CTO DMX values | | | | |
| Colour temperature (K) | DMX value | | | |
| | HP module | | | |
| 2700 | 255 | | | |
| 2800 | 249 | | | |
| 3000 | 236 | | | |
| 3200 | 228 | | | |
| 3600 | 206 | | | |
| 4000 | 183 | | | |
| 4500 | 159 | | | |
| 4800 | 135 | | | |
| 5000 | 113 | | | |
| 5600 | 72 | | | |
| 6000 | 47 | | | |
| 6500 | 0 | | | |
| Note: zoom 128DMX | | | | |