

# ROBE

## ROBIN<sup>®</sup> Spikie

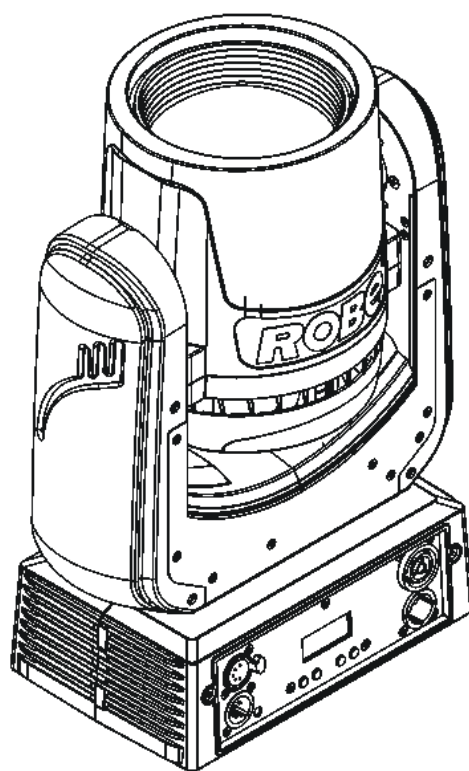

**ROBE**  
Innovative  
Technology

QR code for user manual



### USER MANUAL

ROBE<sup>®</sup> lighting s.r.o. • Czech Republic • [www.robe.cz](http://www.robe.cz)

Version 1.9

# Robin Spikie

## Table of contents

<b>1. Safety instructions</b> .....	<b>3</b>
<b>2. Fixture exterior view</b> .....	<b>5</b>
<b>3. Installation</b> .....	<b>6</b>
3.1 Connection to the mains .....	6
3.2 Rigging the fixture .....	7
3.3 DMX-512 connection.....	9
3.4. Wireless DMX operation .....	10
<b>4. Remotely controllable functions</b> .....	<b>11</b>
<b>5. Control menu map</b> .....	<b>13</b>
<b>6. Control menu</b> .....	<b>15</b>
6.1 Addressing (DMXA).....	15
6.2 Fixture information (Info) .....	15
6.3 Personality (Pers).....	16
6.4 Manual Control (Manual).....	17
6.5 Test program (Test Prg).....	17
6.6 Stand-alone (St Alone) .....	17
6.7 Reset.....	18
6.8 Special functions (Special).....	18
<b>7. RDM</b> .....	<b>21</b>
<b>8. Error and information messages</b> .....	<b>22</b>
<b>9. Technical Specifications</b> .....	<b>23</b>
<b>10. Maintenance and cleaning</b> .....	<b>25</b>
10.1 Replacing the fuse .....	26
10.2 Cleaning of the air filtr .....	27
10.3 Checking plastic parts of the fixture.....	27
10.4 Disposing of the product .....	27
<b>11. Photometric diagrams</b> .....	<b>28</b>
<b>12. ChangeLog</b> .....	<b>32</b>

**FOR YOUR OWN SAFETY, PLEASE READ THIS USER MANUAL CAREFULLY  
BEFORE POWERING OR INSTALLING YOUR ROBIN Spikie !**

**Save it for future reference.**

This device has left our premises in absolutely perfect condition. In order to maintain this condition and to ensure a safe operation, it is absolutely necessary for the user to follow the safety instructions and warning notes written in this manual.

The manufacturer will not accept liability for any resulting damages caused by the non-observance of this manual or any unauthorized modification to the device.

Please consider that damages caused by manual modifications to the device are not subject to warranty.

**The Robin Spikie was designed for indoor use and it is intended for professional application only. It is not for household use.**

## 1. Safety instructions

**DANGEROUS VOLTAGE CONSTITUTING A RISK OF ELECTRIC SHOCK IS PRESENT WITHIN THIS UNIT!**

Make sure that the available voltage is not higher than stated on the rear panel of the fixture. This fixture should be operated only from the type of power source indicated on the marking label. If you are not sure of the type of power supplied, consult your authorized distributor or local power company.

WARNING! This unit does not contain an ON/OFF switch. Always disconnect power input cable to completely remove power from unit when not in use or before cleaning or servicing the unit.

Do not allow anything to rest on the power cord. Do not locate this fixture where the cord may be damaged by persons walking on it.

Make sure that the power cord is never crimped or damaged by sharp edges. Check the fixture and the power cord from time to time.

Refer servicing to qualified service personnel.

**This fixture falls under protection class I. Therefore this fixture has to be connected to a mains socket outlet with a protective earthing connection.**

Do not connect this fixture to a dimmer pack.

**Warning! Risk Group 2 LED product according to EN 62471.  
LED light emission. Risk of eye injury. Do not look into the beam at short distance of the of the product. Do not view the light output with optical instruments or any device that may concentrate the beam.  
The light source contains blue LEDs.**

If the fixture has been exposed to drastic temperature fluctuation (e.g. after transportation), do not switch it on immediately. The arising condensation water might damage your device. Leave the device switched off until it has reached room temperature.

Avoid brute force when installing or operating the fixture.

This fixture was designed for indoor use only, do not expose this unit to rain or use near water.

When choosing the installation spot, please make sure that the fixture is not exposed to extreme heat, moisture

or dust.

Air vents and slots in the fixture's head and base are provided for ventilation, to ensure reliable operation of the device and to protect it from overheating.

**Do not block the front lens with any object when the fixture is under operation.**

The openings should never be covered with cloth or other materials, and never must be blocked.

This fixture should not be placed in a built-in installation unless proper ventilation is provided.

Only operate the fixture after having checked that the housing is firmly closed and all screws are tightly fastened.

Always use a secondary safety cable when rigging this fixture.

Make sure that the area below the installation place is blocked when rigging, derigging or servicing the fixture.

The fixture becomes very hot during operation. Allow the fixture to cool approximately 20 minutes prior to manipulate with it.

Operate the fixture only after having familiarized with its functions. Do not permit operation by persons not qualified for operating the fixture. Most damages are the result of unprofessional operation!

Please use the original packaging if the fixture is to be transported.

Please consider that unauthorized modifications on the fixture are forbidden due to safety reasons!

If this device will be operated in any way different to the one described in this manual, the product may suffer damages and the guarantee becomes void. Furthermore, any other operation may lead to dangers like short-circuit, burns, electric shock, crash etc.

Immunity of the equipment is designed for electromagnetic environments E1, E2, E3 according to the standard EN55103-2 ed.2 Electromagnetic compatibility. Product family standard for audio, video, audiovisual and entertainment lighting control apparatus for professional use. Part 2: Immunity.

The installation company should check levels of possible interferences above the tested levels E1,E2,E3 given by this standard (e.g. transmitters in surrounding area) before installing the equipment.

Emission of the equipment complies with the standard EN55032 Electromagnetic compatibility of multimedia equipment – Emission Requirements according to class B.

**To avoid damage of the internal optical system of the fixture, never let the sunlight or other fixture lights directly to the front lens , even when the fixture is not working !**

**Be careful when the fixture performs fast pan and (or) tilt movement.  
There is a danger of injury of your hands (especially fingers).**

## 2. Fixture exterior view

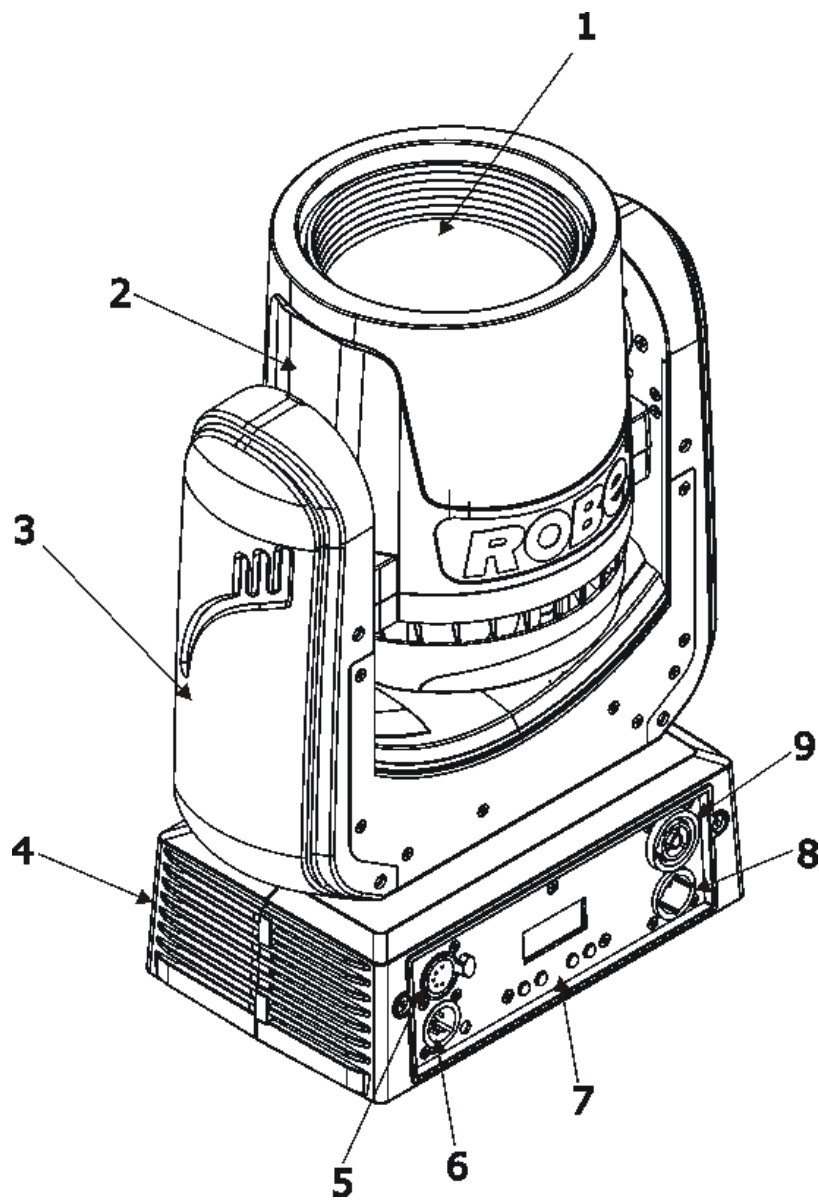

- 1 - Front lens
- 2 - Moving head
- 3 - Yoke
- 4 - Base
- 5 - DMX Out
- 6 - DMX In
- 7 - Control board
- 8 - Mains In
- 9 - Mains Out

### 3. Installation



**Fixtures must be installed by a Qualified electrician in accordance with all national and local electrical and construction codes and regulations.**

#### 3.1 Connection to the mains

**For protection from electric shock, the fixture must be earthed!**

The Robin Spikie is equipped with auto-switching power supply that automatically adjusts to any 50-60Hz AC power source from 100-240 Volts.

If you install a cord cap on the power cable to allow connection to power outlets, install a grounding-type (earthed) plug, following the plug manufacturer's instructions.

If you have any doubts about proper installation, consult a qualified electrician.

Core (EU)	Core (US)	Connection	Plug Terminal Marking
Brown	Black	Live	L
Light blue	White	Neutral	N
Yellow/Green	Green	Earth	

This device falls under class one and must be earthed (grounded)!

Design of the Robin Spikie allows to connect several fixtures to AC mains power in one interconnected daisy chain using power input and throughput connectors. Needed daisy chain cords are stated in the chapter "Technical specifications"

The max. number of connected fixtures depends on the AC mains power voltage and fixture version:

EU version (CE)

29 fixtures at power supply= 230V

26 fixtures at power supply= 208V

15 fixtures at power supply= 120V

US version (cETLus)

17 fixtures at power supply= 230V

15 fixtures at power supply= 208V

9 fixtures at power supply= 120V

Actual numbers of fixtures may differ from values stated above as you have to take into account the length of supply cables, circuit breaker etc. at projecting of the fixtures installation Do not overload the supply line and the connecting leads.

Wiring and connection work must be carried out by qualified staff!

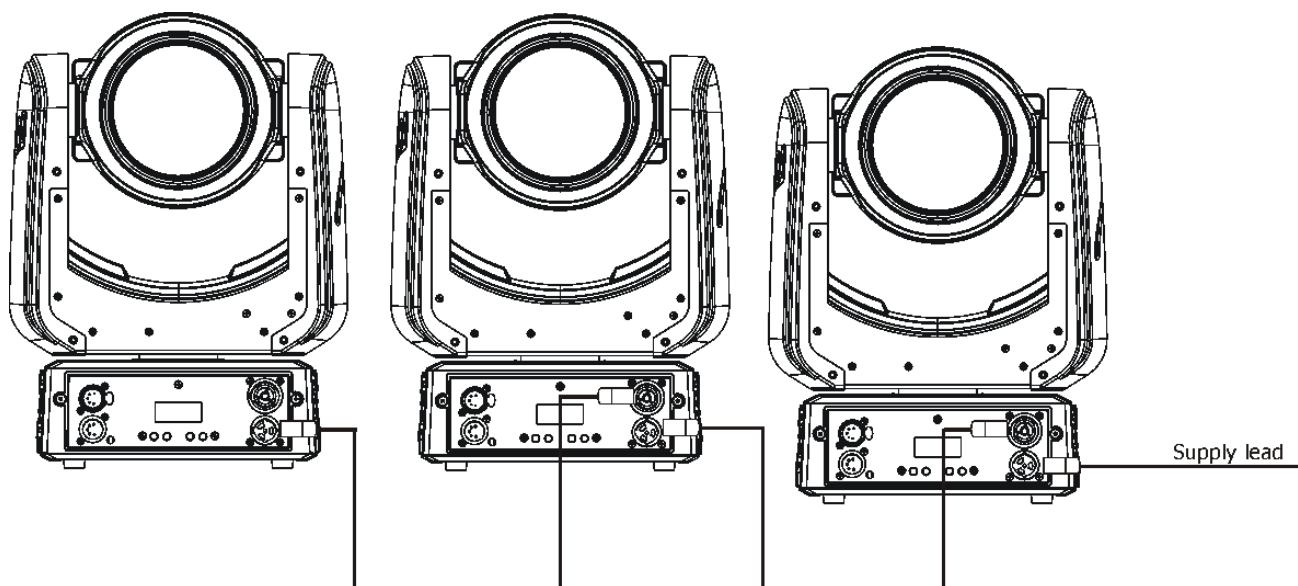

### 3.2 Rigging the fixture

A structure intended for installation of the fixture (s) must safely hold weight of the fixture(s) placed on it. The structure has to be certificated to the purpose.

The fixture (fixtures) must be installed in accordance with national and local electrical and construction codes and **regulations**.

**For overhead installation, the fixture must be always secured with a safety wire that can bear at least 10 times the weight of the fixture.**

When rigging, derigging or servicing the fixture staying in the area below the installation place, on bridges, under high working places and other endangered areas is forbidden.

The operator has to make sure that safety-relating and machine-technical installations are approved by a skilled person once a year.

The fixture should be installed outside areas where persons may walk by or be seated.

**IMPORTANT! OVERHEAD RIGGING REQUIRES EXTENSIVE EXPERIENCE**, including (but not limited to) calculating working load limits, installation material being used, and periodic safety inspection of all installation materials and the fixture. If you lack these qualifications, do not attempt the installation yourself, but instead use a professional structural rigger. Improper installation can result in bodily injury or damage to property. The fixture has to be installed out of the reach of people.

The fixture must never be fixed swinging freely in the room.

**Caution:** Fixture may cause severe injuries when crashing down! If you have doubts concerning the safety of a possible installation, do not install the moving head!

Before rigging make sure that the installation area can hold a minimum point load of 10 times the fixture's weight.

**When installing the device, make sure there is no highly inflammable material (decoration articles, etc.) in a distance of min. 0.4 m.**

**CAUTION!**  
**Use an appropriate clamp to rig the fixture on the truss.**  
**Make sure that the device is fixed properly! Ensure that the structure (truss) to which you are attaching the fixture is secure.**

The fixture can be placed directly on the stage floor or rigged on a truss without altering its operation characteristics.

**Due to very fast pan/tilt movement of the fixture, the fixture has to be always anchored to the ground (base) otherwise there is a danger of knocking the fixture over.**

For securing the fixture to the truss install a safety wire that can hold at least 10 times the weight of the fixture.

Use only the safety wire with a snap hook with screw lock gate. Fasten the snap hook in the attachment point and the safety wire around the truss as shown on the picture below.

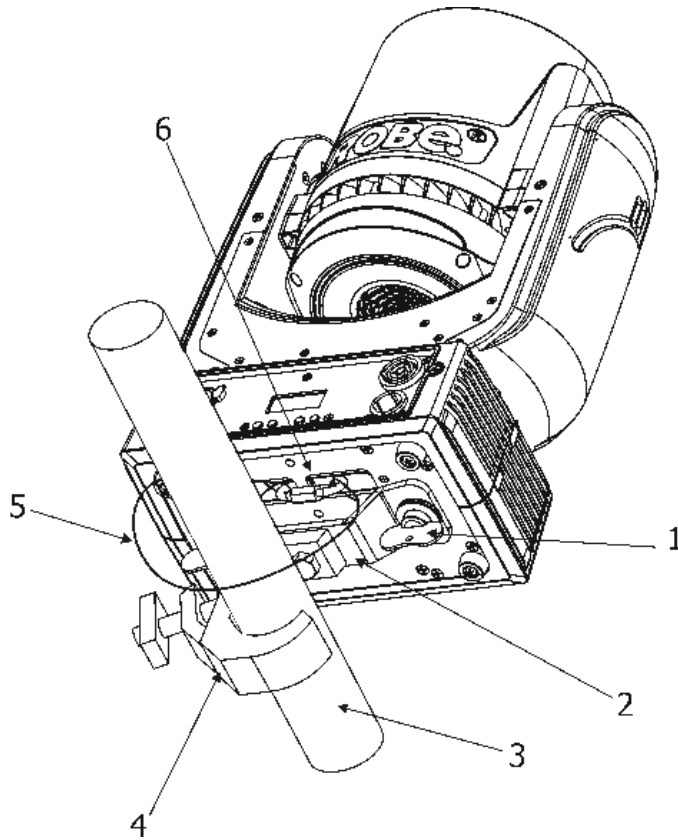

- 1-Quick-lock fastener
- 2-Omega holder
- 3-Truss
- 4-Clamp
- 5-Safety wire with a snap hook  
with screw lock gate
- 6-Attachment point

**When installing fixtures side-by-side, avoid illuminating one fixture with another!**



### 3.3 DMX-512 connection

The fixture is equipped with 5-pin XLR sockets for DMX input and output. Only use a shielded twisted-pair cable designed for RS-485 and 5-pin XLR-plugs and connectors in order to connect the controller with the fixture or one fixture with another.

#### DMX output

XLR socket:



- 1 - Shield
- 2 - Signal (-)
- 3 - Signal (+)
- 4 - Used for wireless DMX
- 5 - Used for wireless DMX

#### DMX input

XLR plug:



- 1 - Shield
- 2 - Signal (-)
- 3 - Signal (+)
- 4 - Used for wireless DMX
- 5 - Used for wireless DMX

If you are using the standard DMX controllers, you can connect the DMX output of the controller directly with the DMX input of the first fixture in the DMX-chain. If you wish to connect DMX-controllers with other XLR-outputs, you need to use adapter-cables.

#### Building a serial DMX-chain:

Connect the DMX-output of the first fixture in the DMX-chain with the DMX-input of the next fixture. Always connect one output with the input of the next fixture until all fixtures are connected. Up to 32 fixtures can be interconnected.

**Caution:** At the last fixture, the DMX-cable has to be terminated with a terminator. Solder a 120  $\Omega$  resistor between Signal (-) and Signal (+) into a 5-pin XLR-plug and plug it in the DMX-output of the last fixture.

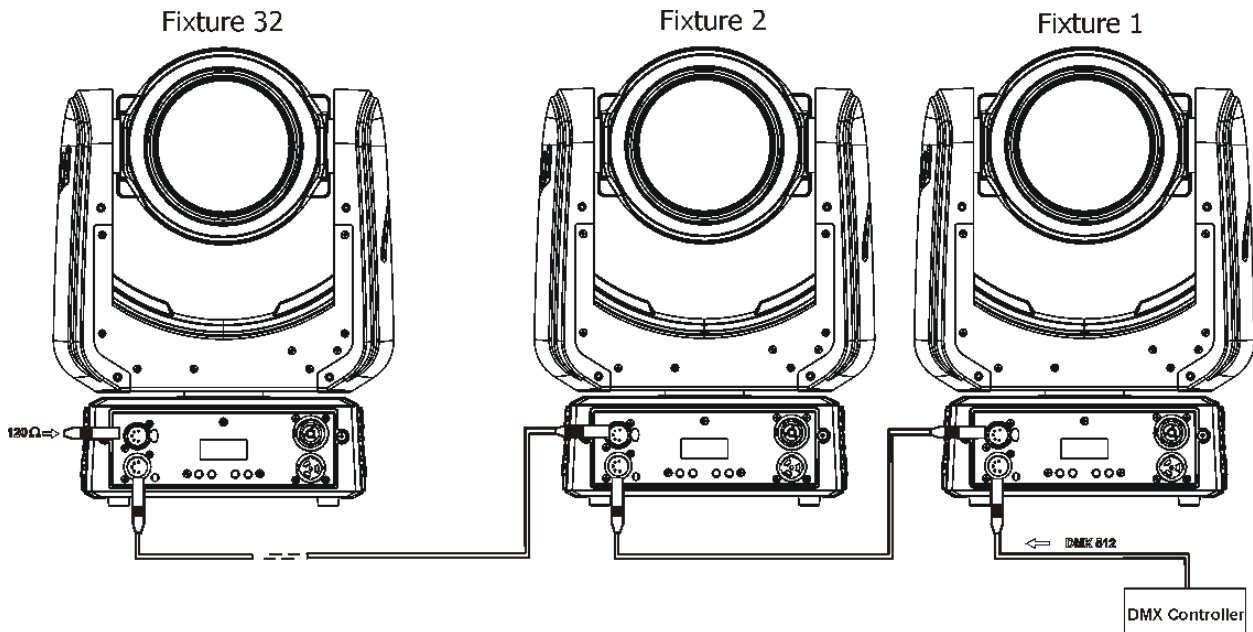

### 3.4. Wireless DMX operation

The external ROBE Wireless CRMX Dongle for compact ROBIN fixtures allows receiving wireless DMX. This module is equipped with the Lumen Radio CRMX module and antenna for receiving DMX signal. CRMX module operates on the 2.4 GHz band.

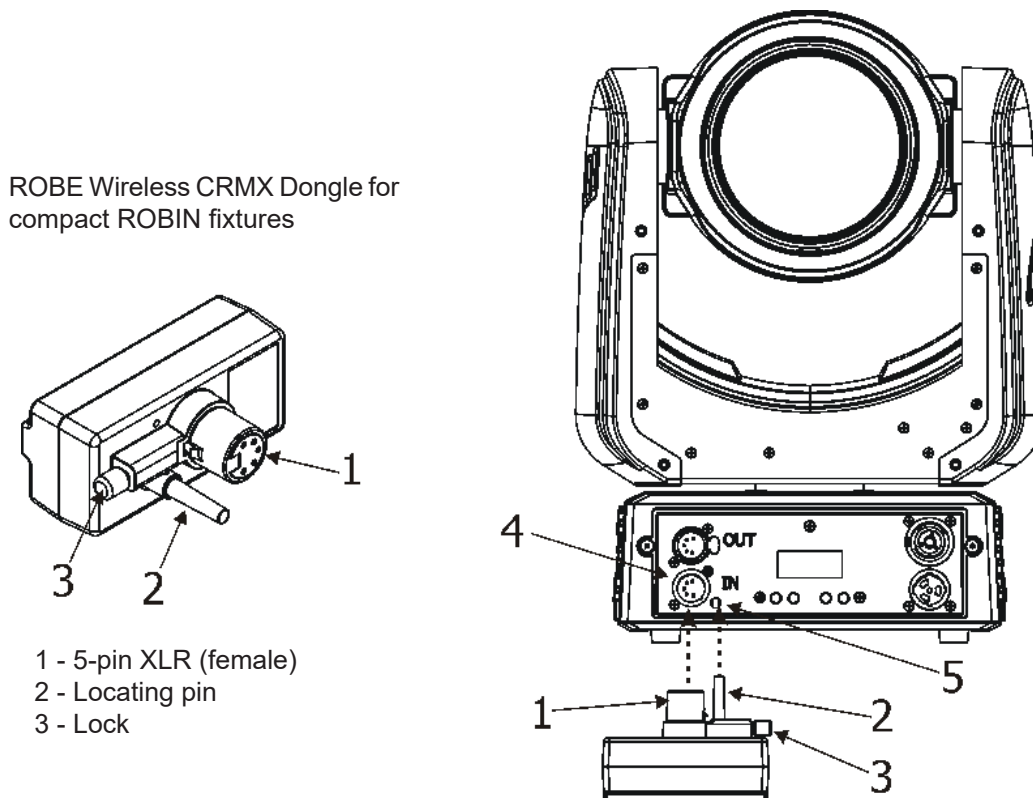

Push in the 5-pin XLR plug (1) into 5-pin XLR socket (4) and simultaneously locating pin (2) into hole (5) in the fixture. In this way the wireless DMX module is connected with the fixture.

NOTE: when you disconnect the DMX wireless module from fixture, press and hold lock (5) during getting the wireless module out.

#### To link the fixture with DMX transmitter.

The fixture can be only linked with the transmitter by running the link procedure at DMX transmitter. After linking, the level of DMX signal (0-100 %) is displayed in the menu item "Stat" (Special -->Wireless -->Stat).

#### To unlink the fixture from DMX transmitter.

The fixture can be unlinked from receiver via the menu item "Unlink" (Special-->Wireless -->Unlink).

## 4. Remotely controllable functions

### Virtual Colour wheel

The virtual colour contains 68 preset colours, rainbow effect in both directions with variable speed.

### CTC (colour temperature correction)

The CTC channel allows to change colour temperature of white in range of 2700K-8000K.

### Colour Mix control

The Colour Mix control channel defines relation between colour channels (R,G,B,W) and virtual colour wheel:

DMX value	Function
0-9	Virtual colour wheel has priority
10-19	Maximum mode (highest values have priority)
20-29	Minimum mode (lowest values have priority)
30-39	Multiply mode (multiply Virtual colour wheel and Colour channels)
40-49	Addition mode (Virtual colour wheel + Colour channels) - default
50-59	Subtraction mode (Virtual colour wheel – Colour channels)
60-69	Inverted Subtraction mode (Virtual colour wheel – Colour channels)
70-128	reserved
129	Virtual colour wheel has priority
130-254	Cross fade between Virtual colour wheel and colour channels
255	Colour channels have priority

### Prism

The 3-facet prism rotates in both directions at different speeds.

### Flower Effect

The Flower effect rotates in both directions with variable speed. 10 Flower effect macros are created.

### Zoom

The motorized zoom module allows beam range of 4° - 27°.

### Dimmer/Shutter unit

Smooth 0 - 100 % dimming is provided by the electronic control unit. This unit is also used for strobe effects with variable speed.

### Pan/Tilt

Pan/tilt movement range: 540°/360°, continual pan/tilt rotation.

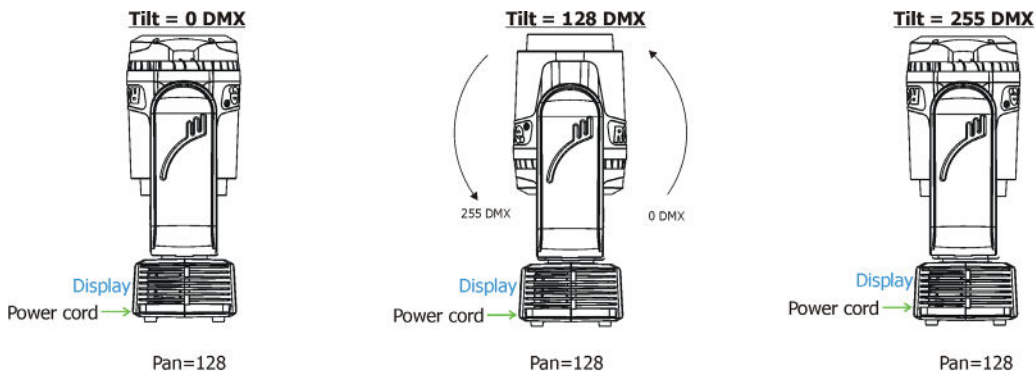

**Tilt movement range: 360° Pan movement range: 540°**

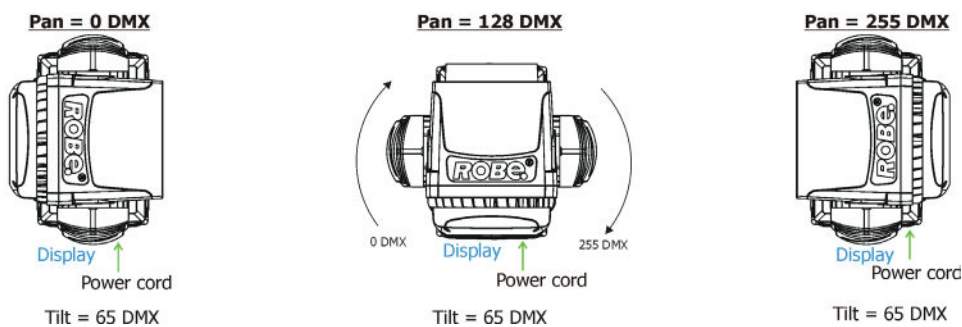

## Continual rotation

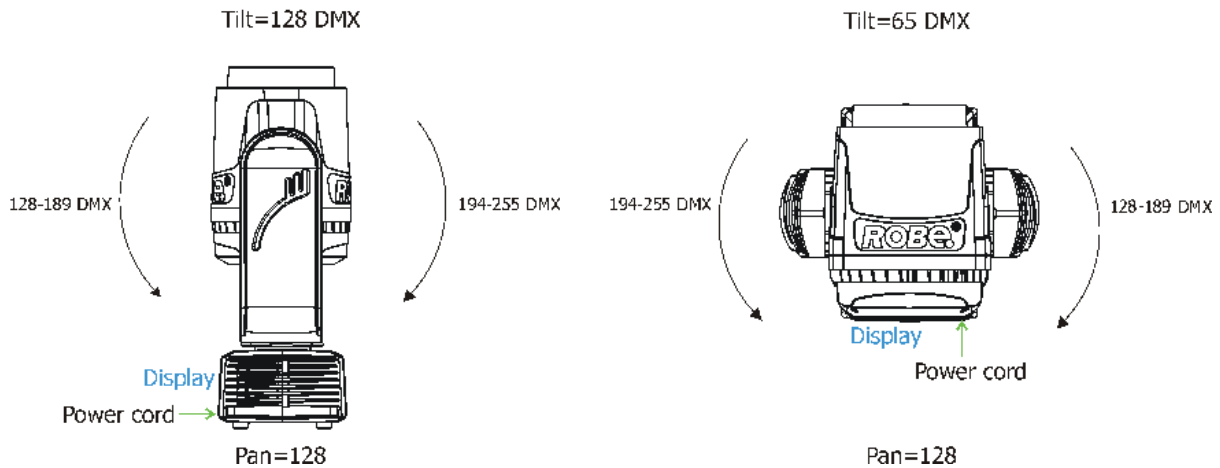

### Pan control/Tilt control channels

Pan control (Tilt control) channel = 0 DMX (default value) - if the pan (tilt) receives a value 255 DMX from a DMX controller and next received DMX value for the pan (tilt) will be 0 DMX, the pan (tilt) will move to the point 0 DMX around entire track 255-0 DMX.

Pan control (Tilt control) channel = 1 DMX - if the pan (tilt) receives a value 255 DMX from a DMX controller and next received DMX value for the pan (tilt) will be 0 DMX, the pan (tilt) will move to the point 0 DMX directly without changing its direction of movement.

Examples for tilt movement:

Tilt control = 0 DMX (default)

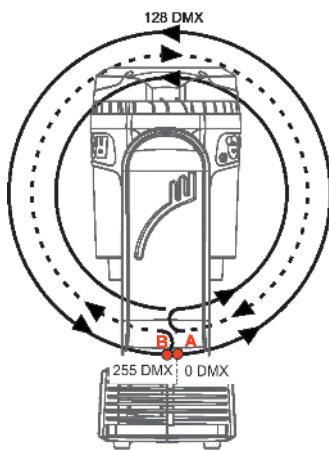

DMX controller sends tilt DMX values 0,1,2,...254,255,0,1... repeatedly.

The head moves from the point A (0 DMX) to the point B (255 DMX) and from the point B returns to the point A (0 DMX) and continues in movement to the point B.

Tilt control = 1 DMX

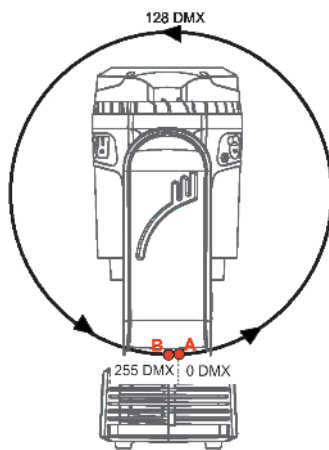

DMX controller sends tilt DMX values 0,1,2,...254,255,0,1... repeatedly.

The head moves from the point A (0 DMX) to the point B (255 DMX) and continues in movement to the point A (0 DMX) in the same direction (without changing direction of its movement).

Tilt control = 1 DMX

Example of blackout in certain positions of head

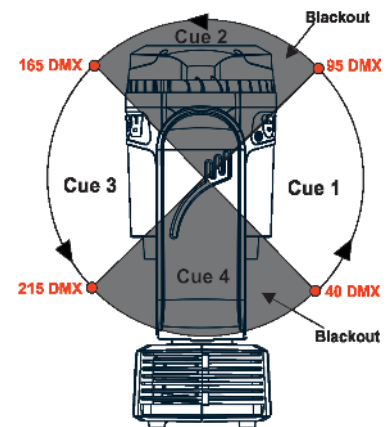

The four cues are repeated in the order: Cue 1, Cue 2, Cue 3, Cue 4, Cue 1....

Tilt DMX values are changing in the cues as follows:

Cue 1: 40, 41...94,95.  
 Cue 2: 96, 97....164,165.  
 Cue 3: 166,167....214,215.  
 Cue 4: 216,217....38,39

The dimmer is closed in Cues 2 and 4.

## 5. Control menu map

Default settings=**Bold print**

Level 1	Level 2	Level 3	Level 4	Level 5	Level 6	Level 7
<b>DMXA</b>	Set DMXA	001-512				
	DMX Pres	<b>Mode 1</b>				
		Mode 2				
<b>Info</b>	POn Time	Total				
		Reset				
	Air fil	Aler P				
		R Ti				
	DMX In	Pan	0-255			
		:				
		Dim F	0-255			
	Hea Temp	Current				
		Highest				
		High Res				
	Bas. Temp	Current				
		Highest				
		High Res				
	Sw Ver	IC-1				
		IC-2				
		IC-3				
		IC-4				
<b>Pers</b>						
	DMX Pres	<b>Mode 1</b>				
		Mode 2				
	Pan Rev	On, <b>Off</b>				
	Tilt Rev	On, <b>Off</b>				
	P/T Mode	<b>Speed</b>				
		Time				
	P/T Feed	<b>On, Off</b>				
	Display	Turn				
		On/Off T	<b>On, Off</b>			
		Contrast	0-100%			
		Backlight	0-100%			
	BLC DMC	On, <b>Off</b>				
	BLC P/T	On, <b>Off</b>				
	Comp	On, <b>Off</b>				
	C Mix M	<b>RGBW, CMY</b>				
	White P	<b>On, Off</b>				
	Dimmer C	<b>Square, Linear</b>				
	LED Freq	<b>Stand</b>				
		High				
	LED Fadj	-06,-05..00..05, 06				
	Mic Sens	0... <b>10</b> ...19				
	Fans	<b>Auto, High</b>				
	Temp Uni	<b>°C, °F</b>				
	I Ef Pos	Pan				
		:				
		Dim F				
		Store				
	Defaults					

Level 1	Level 2	Level 3	Level 4	Level 5	Level 6	Level 7
<b>Manual</b>		Pan	0-255			
		:				
		Dim F	0-255			
<b>Test Prg</b>	Static	Pan	0-255			
		Tilt	0-255			
		Run				
	Dynamic					
<b>Sta Alone</b>	Music T	On, <b>Off</b>				
	Auto Run	<b>Off</b>				
		Test				
		Prog 1				
		Prog 2				
		Prog 3				
	Pr Play	Test Prg				
		Prog 1				
		Prog 2				
		Prog 3				
	Pr Edit	Prog 1	Step 1	Pan		
		Prog 2	:	:		
		Prog 3	Step 40	F.Tim	0-25.5	
				S.Tim	0-25.5	
				COPY		
				Prg En	1-40	
<b>Reset</b>						
<b>Special</b>	RDM Low					
	RDM Hight					
	Wireless	Stat				
		Unlink				
	Adjust	DMX Val	Pan	0-255		
			:			
			Dim F	0-255		
		Calib	Cal Mech	Pan C	0-255	
				Tilt C	0-255	
				Pr1 C	0-255	
				Pr2 C	0-255	
				Fl1 C	0-255	
				Fl2 C	0-255	
				Zoom	0-255	
				Store		
			Cal Col	Red C	0-255	
				Gren C	0-255	
				Blue C	0-255	
				Whit C	0-255	
				Red I	0-255	
				Gre I	0-255	
				Blu I	0-255	
				Whi I	0-255	
				Store		
			Cal Load			
	Sw Upd	On, <b>Off</b>				

## 6. Control menu

The Robin Spikie is equipped with 2-row LCD display which allows to set the fixture's behaviour according to your needs, obtain information on its operation, test its various parts and lastly program it, if it has to be used in a stand-alone mode.

Control panel:

[ESCAPE] button used to leave the menu without saving changes.

[NEXT] , [PREV] buttons for moving between menu items and for value adjusting.

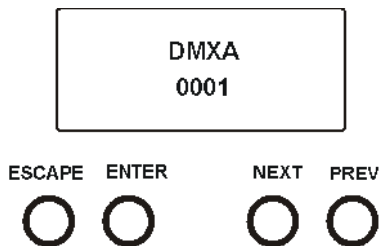

[ENTER] button used to enter the selected menu (menu item) and to confirm adjusted value.

After switching the fixture on, display shows current DMX address.

### 6.1 Addressing (DMXA)

**Set DMXA-** Use this menu item to set the DMX start address of the fixture, which is defined as the first channel from which the Robin Spikie will respond to the controller.

If you set, for example, the address 36, the Robin Spikie will use channels 36 - 70 for control (if Mode 1 is selected).

Please, be sure that you do not have any overlapping channels in order to control each Robin Spikie correctly and independently from any other fixture on the DMX data link.

If there is no data received at the DMX input, the display will start to flash "0001" with actually stored DMX address.

**DMX Pres - DMX preset.** Use the menu to select desired channel mode.

**Mode 1** - 27 control channels

**Mode 2** - 21 control channels

### 6.2 Fixture information (Info)

**Pon Time - Power on time.** Select this menu to read the number of fixture operation hours.

**Total** - The item shows the total number of the operation hours since the Robin Spikie has been fabricated.

**Reset** - The item shows the number of the operation hours that the Robin Spikie has been powered on since the counter was last reset.

In order to reset this counter to 0, press and hold both [NEXT] and [PREV] buttons and the [Enter] button at the same time.

**Air fil - Air filter.** Regular cleaning of the air filter in the fixture base is very important for the fixture's life and performance. Build-up of dust, dirt and fog fluid residues reduces the fixture's fan ability.

he two items of this menu help you to keep cleaning period of the air filter.

**Alert P** - Cleaning schedule for the fixture depends on the operating environment.

It is therefore impossible to specify accurate cleaning interval. This item allows you to change the cleaning interval of the air filter. This "alert" value is 300 hours and it is set as default. Inspect the fixture within its 300 hours of operation to see whether cleaning is necessary. If cleaning is required, clean air filter and change the value in this menu on acceptable level. Min. level of alert period is 10 hours, max. is 300 hours.

**R Ti** - The item allows you to read the time which remains to cleaning air filter.

The time period is set in the menu mentioned above.

To reset this menu item press and hold both [NEXT] and [PREV] buttons and the [Enter] button at the same time.

**DMX In - DMX readout.** The menu is used to read DMX values of each channel received by the fixture.

**Hea Temp - Head temperature.** The menu shows temperature in the fixture's head.

**Current** - A current temperature of the head.

**Highest** - A maximum temperature of the the head since the fixture has been fabricated.

**High Res** - A maximum temperature of the the head since the counter was last reset.

In order to reset this counter, press and hold both [NEXT] and [PREV] buttons and the [Enter] button at the same time.

**Sw Ver - Software versions.** Select this item to read the software version of the fixture modules.

**IC-1** - A pan/Tilt processor.

**IC-2** - A display processor.

**IC-3** - LED control processor.

**IC-4** - LED control processor.

## 6.3 Personality (Pers)

**DMX Pres - DMX preset.** Use the menu to select desired channel mode.

**Mode 1** - 27 control channels

**Mode 2** - 21 control channels

**Pan Rev - Pan reverse.** The item allows to invert pan movement.

**Tilt Rev - Tilt reverse.** The item allows to invert tilt movement.

**P/T Mode - Pan and Tilt movement mode.** Use this menu to set mode of the pan/tilt movement.

**Speed** - Both Pan and tilt will move with the same speed as adjusted at the channel "Pan/Tilt speed, Pan/Tilt time".

**Time** - The pan and tilt will move with different speeds and they will come at the same time to the end point of their tracks (pan and tilt use their optimal speeds). Time of the pan/tilt movement (25.5 sec. max.) is set by the channel "Pan/Tilt speed, Pan/Tilt time".

**P/T Feed - Pan and Tilt Feedback.** The menu item allows to return the moving head to the required pan/tilt position after changing the position by an external force if this option is set on.

Note. The Pan/Tilt Feedback should be permanent On, the option Off is not suitable for standard operation and the head of the fixture can be damaged!

**Display - Display adjusting.** This menu allows you to adjust the display behaviour.

**Turn** - This function rotates menu 180 degrees from current orientation..

**On/Off T** - This function allows you to keep the display permanent on (On/Off T= Off) or turn it off two minutes after last pressing any button on the control panel (On/Off T= On).

**Contrast**- Use this function to adjust contrast of the display (0-100%).

**Backlight**- Use this function to adjust backlight of the display (0-100%).

**BLC DMC - Blackout during movement correction.** Set this option on if you wish to close light output during the time when the head goes to its correct position, which has been changed by an external force.

**BLC P/T - Blackout at P/T movement.** The menu item allows to close light output while pan/tilt coordinates are changing.

**Comp - Intensity compatibility.** The menu item is intended for the Spikie+ only, for Spikie has to be set off.

**C Mix M - Colour mixing mode.** This item allows switching into RGBW or CMY mode. In the CMY mode, the white(8bit)/white (16) bit channels are not active.

**White P - White Point 8000K.** If the function is on, the CTC channel allows to set desired white in range of 8000K-2700K

(0 DMX=8000K, 255 DMX=2700K). Necessary condition is , that RGBW channels have to be full or set at the same DMX values, e.g. 150.

If this function is off, the range of whites is not uniform and may be different for each fixture.



**Mic Sens - Microfon sensitivity.** Enter the menu if you want to adjust the microphone sensitivity ( 0-max., 19-min.).

**Dimmer C - Dimmer curve.** Use the menu to select desired dimmer curve.

**Linear** - a linear curve.

**Square** - a square law curve.

**LED Freq - LEDs frequency setup.** The function allows you to set the PWM (Pulse Width Modulation) output frequency of LEDs to Standard or High.

**Stand** - a standard frequency (300Hz), default setting.

**High** - a high frequency (600Hz)

**LED Fadj - LEDs frequency fine adjustment.** The function allows you to change the selected PWM output frequency of LEDs in 6 levels up and down around the selected frequency in the menu "LED Freq".

-06...-01 - Frequence levels 1-6 under selected frequency.

00 - Selected frequency (Standard or High)

01...06 - Frequence levels 1-6 above selected frequency.

**Fans - Fan mode.** Use the menu to set the fixture fans to max. fan power mode ("High") or to auto-control mode ("Auto").

**Temp Uni - Temperature unit.** Use the menu item to change temperature unit from °C to °F.

**I Ef Pos - Init effect positions.** Use the menu to set all effects to the desired positions at which they will stay after switching the fixture on without DMX signal connected.

**Defaults** - The menu item allows to set all fixture parameters to the default (factory) values.

## 6.4 Manual Control (Manual)

Use the menu to control all fixture channels by means of the control panel.

## 6.5 Test program (Test Prg)

Use this menu to to run demo test sequences without an external controller, which will show you some possibilities of using Robin Spikie.

**Static - Static mode.** This mode is suitable for projections on the wall, ceiling or ground without any head movement.

**Dynamic - Dynamic mode.** This mode uses all Robin Spikie functions including pan/tilt movement and therefore is good for a complete introduction of the fixture.

## 6.6 Stand-alone (St Alone)

**Music T - Music trigger.** Select this function to enable the sound control of the running program via the built-in microphone.

**Auto Run - Presetting playback.** This function allows you to select the program which will be played in the stand-alone mode after switching the fixture on. Selected program will be played continuously in a loop.

**Off** - The option disables „Auto Run” function.

**Test** - The option will start built-in test program.

**Prog 1** - The option will start user-created program 1

**Prog 2** - The option will start user-created program 2

**Prog 3** - The option will start user-created program 3

**Pr Play - Playing program.** Select this menu to run a user-created program in a loop.

**Test Prg** - The option runs built-in test program.

**Prog 1** - The option runs user-created program 1

**Prog 2** - The option runs user-created program 2

**Prog 3** - The option runs user-created program 3

Select the program you wish and press [ENTER]. The selected program starts running. By Pressing [ENTER] again, program pauses running.

**Pr Edit - Editing program.** Select this menu to edit or create the program. The Robin Spikie has one built-in program and one user-editable program up to 40 steps. Each program step has a step time - during which effects last in the current step and a fade time- during which effects move to new positions.

To edit program:

1. Press [NEXT] or [PREV] to select the menu "Edit" and press [ENTER].
2. Press [NEXT] or [PREV] to select the desired program step and press [ENTER] button.
3. Press [NEXT] or [PREV] to select the desired item and press [ENTER] button. Now you can edit by [NEXT] or [PREV] buttons the DMX value (0-255) for selected item:

Prg End.	a total number of the program steps (value 1-40). This value you should be set before starting of programming (e.g. if you want to create program with the 10 steps, set Prg End=10).
PAn	a coarse pan movement
PAn F	a fine pan movement
Tilt	a coarse tilt movement
Tilt F	a fine tilt movement
Pan C	a pan continual movement
Tilt C	a tilt continual movement
P/T Sp	a pan/tilt speed
Powr	power/special functions
Virt C	a virtual colour wheel
Red	a red colour coarse
Red F	a red colour fine
Green	a green colour coarse
Green F	a green colour fine
Blue	a blue colour coarse
Blue F	a blue colour fine
White	a white colour
White F	a white colour fine
CTC	a colour temperature correction
C Mix C	a colour mix control
Prism	a rotating prism
Flow E	a flower effect
Flow ER	a flower effect rotation
Zoom	a zoom function
Zoom F	a zoom function fine
Stro	a strobe/shutter function
Dimm	a dimmer function coarse
Dim F	a dimmer function fine
F.Tim	a fade time (0-25.5 sec)
S.Tim	a step time (0-25.5 sec)
COPY	copying the current prog. step to the next prog. step

4. Press [ENTER] button to confirm adjusted value .
5. Press [ESCAPE] button, select next prog. step, press [ENTER] button and repeat steps 3 - 5).

## 6.7 Reset

This option enables the Robin Spikie to index all effects and return to their standard positions.

## 6.8 Special functions (Special)

**RDM Low** - This menu item shows the first part of the RDM identification code.

**RDM High** - This menu item shows the second part of the RDM identification code.

**Wireless - Stat** - Use the menu to read wireless DMX status.

**Unlink** - use this item to unlink fixture from wireless DMX.

**Adjust - Adjustment.** The menu allows the fine adjustment of effects.

**DMX Val- DMX values.** Use the menu to set DMX values of fixture's channels.

**Calib** - calibration fixture effects.

**Cal Mech** - Use this menu to calibrate mechanical effects:

- Pan C - position of the pan
- Tilt C - position of tilt
- Pr1 C - position of prism
- Pr2 C - prism rotation
- F11 C - flower effect frost movement
- F12 C - flower effect rotation fine
- Zoom - Zoom position fine

**Cal Col** - The menu serves for calibration of colours in the factory.

Items **Red C**, **Gre C**, **Blu C** and **Whi C** serve for setting of white colour 5600K.

Items **Red I**, **Gre I**, **Blu I** and **Whi I** serve for setting of colour intensities.

*Calibration of the pan/tilt via the control board*

1. Disconnect DMX controller from the fixture and enter the "Cal P/T" menu.
2. Use the [PREV] and [NEXT] to find "Pan" and press [ENTER].
3. Set desired value and save it by pressing [ENTER].
4. Repeat steps 2 and 3 for Tilt.
5. After calibrating both effects, find item "Store" and press [ENTER]. to save all adjusted values and reset the fixture.

*Calibration of the white 5600K via the control board*

1. Disconnect DMX controller from the fixture, set the shutter, dimmer and RGBW channels at 255 DMX, zoom at 128 DMX and the CTC channel at DMX=64 (white 5600K). Aim the light beam on the lux meter (e.g. Minolta CL-200A Chroma meter) which is placed cca 5m from the fixture.
2. Set the menu items Colour Mix Mode to RGBW and "White Point 8000K to On (Pers-> C Mix M -> RGBW, Pers-> White P -> On).
3. Enter the menu "Cal Col".
4. Use the [NEXT] or [PREV] button to select desired colour and press the [ENTER] button.
5. Use the [NEXT] or [PREV] button to set desired value of the colour.
5. By means of the "Red C, Gre C, Blu C and Whi C" items adjust the 5600K colour temperature as exactly as possible ( $\Delta u'v' = 0$ ).
7. After adjusting 5600K colour temperature, select item Store and press the [ENTER] button to save all adjusted values.

Note: you can also use DMX controller for both calibrations stated above, calibration protocol is the following:

<b>Effect</b>	<b>Mode 1</b>	<b>Mode 2</b>
Pan-fine adjustment	channel 27	channel 22
Tilt - fine adjustment	channel 28	channel 23
Prism - position fine	channel 29	channel 24
Prism - rotation fine	channel 30	channel 25
Flower effect frost movement	channel 31	channel 26
Flower effect rotation	channel 32	channel 27
Zoom	channel 33	channel 28
Red - red saturation	channel 34	channel 29
Green- green saturation	channel 35	channel 30
Blue - blue saturation	channel 36	channel 31
White - white saturation	channel 37	channel 32

**Cal Load** - Loads default (factory) calibration.

**Sw Upd** - **Software update.** The menu item allows you to update software in the fixture via either serial or USB port of PC.

The menu item allows you to update software in the fixture via either serial or USB port of PC.

The following items are required in order to update software:

- PC running Windows or Linux or macOS
- DSU file
- Flash cable RS232/DMX, P/N13050624 (if you want to use a serial port of PC)
- Robe Universal Interface or Robe Universal interface WTX (if you want to use an USB port of PC)

After the software updating the fixture will be set to default values.

To update software in the fixture:

1. DSU file is available from Robe web site at [WWW.robe.cz](http://WWW.robe.cz).

File with extension zip is intended for Windows (used and tested from XP to W10 on 32/64bit systems).

File with extension tbz is intended for Linux (used and tested on Debian and Ubuntu 32/64bit).

File with extension dmg is intended for macOS (used and tested on OSX up to Sierra) XQuartz required, install it from <https://www.xquartz.org/>

Save the download file to a folder on your computer.

In case that you use windows, extract files in the zip file (e.g. DSU\_RobinSpikie\_21081742.zip)

2. Disconnect the fixture from DMX controller.

3. If you use the flash cable RS232/DMX, connect a serial port of your computer with DMX input of the fixture by means of the cable.

If you use the Robe Universal Interface, connect a USB port of your computer with the Robe Universal Interface by means of the USB cable and DMX input of the fixture with the DMX output of the Robe Universal Interface via a DMX cable.

4. Switch the fixture to the update mode (Special --> SW Upd -> On).

Note: If you do not want to continue in the software update, you have to switch off and on the fixture to escape from the updating mode.

We recommend to cancel all running programs on your computer before starting the software update.

5. Double-click the software uploader file (e.g. DSU\_RobinSpikie\_21081742.exe) in the extracted files. The Software Uploader program will start running.

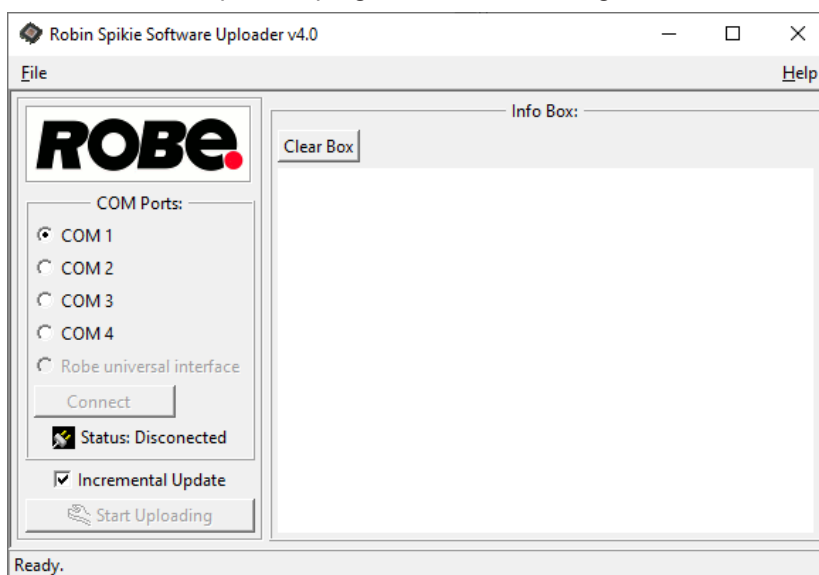

6. Select correct "COM " number if you use a Flash cable RS232/DMX or select "Robe Universal Interface " if you use the Robe Universal Interface/Robe Universal Interface WTX and then click on the "Connect" button.

7. If the connection is OK, click the "Start Uploading" button to start software uploading. It will take several minutes to perform software update.

If the option "Incremental Update" is not checked, all processors will be updated (including processors with the same software version).

If you wish to update only processors with new version of software, check the "Incremental Update box".

Avoid interrupting the process. Update status is being displayed in the "Info Box" window.

When the update is finished, the line with the text "Fixture is successfully updated" will appear in this window.

In case upload process is interrupted (e.g. power loss), the fixture stays in "Updating mode" and you will have to repeat the software update again.

## 7. RDM

This fixture supports RDM operation. RDM (Remote Device Management) is a bi-directional communications protocol for use in DMX512 control systems, it is the new open standard for DMX512 device configuration and status monitoring.

The RDM protocol allows data packets to be inserted into a DMX512 data stream without adversely affecting existing non-RDM equipment. By using a special „Start Code,“ and by complying with the timing specifications for DMX512, the RDM protocol allows a console or dedicated RDM controller to send commands to and receive messages from specific moving lights.

RDM allows explicit commands to be sent to a device and responses to be received from it.

The list of commands for Robin Spikie is the following.

Parameter ID	Discovery command	SET command	GET command
DISC_UNIQUE_BRANCH	*		
DISC_MUTE	*		
DISC_UN_MUTE	*		
DEVICE_INFO			*
SUPPORTED_PARAMETERS			*
SOFTWARE_VERSION_LABEL			*
DMX_START_ADDRESS		*	*
IDENTIFY_DEVICE		*	*
DEVICE_MODEL_DESCRIPTION			*
MANUFACTURER_LABEL			*
DEVICE_LABEL		*	*
SENSOR_DEFINITION			*
SENSOR_VALUE			*
DISPLAY_INVERT		*	*
DISPLAY_LEVEL		*	*
PAN_INVERT		*	*
TILT_INVERT		*	*
DEVICE_RESET		*	
DMX_PERSONALITY		*	*
DMX_PERSONALITY_DESCRIPTION			*
STATUS_MESSAGES			*
STATUS_ID_DESCRIPTION			*
DEVICE_HOURS			*
PARAMETER_DESCRIPTION			*
ROBE_DMX_INPUT		*	*
ROBE_WIRELESS_UNLINK		*	

## 8. Error and information messages

### Tilt Err

This message will appear after the reset of the fixture if the head's magnetic-indexing circuit malfunctions (sensor failed or magnet is missing) or the stepping motor is defective or its driving IC on the PCB. The head is not located in the default position after the reset.

### Pan Err

This message will appear after the reset of the fixture if the head's magnetic-indexing circuit malfunctions (sensor failed or magnet is missing) or the stepping motor is defective or its driving IC on the PCB. The head is not located in the default position after the reset.

### Zoom Err

The messages will appear after the reset of the zoom module if the zoom lens is not located in the default position.

### Prism Err

The messages will appear after the reset of the if the prism is not in the default position.

### Rod Err

The messages will appear after the reset of the flower effect if the rod is not in the default position.

### Short Err

The message informs you that short circuit has occurred on the LED PCB.

### Clean Air Fil

This icon signalizes that cleaning period of the air filter has elapsed and you have to clear air filter in the fixture base and reset the menu item "R Ti".

## 9. Technical Specifications

### Electrical

Power supply: electronic auto-ranging  
Input voltage range: 100-240V, 50-60Hz  
Fuse: T 2A/250V ~  
Max. power consumption: 100W@230V (I=0.48A, power factor=0.88)

Mains input: CE - max. 16A  
ETL - max. 10A  
Mains output: CE - max. 15A  
ETL - max. 9A

### Optic

Light source: 60W RGB LED multichip)  
Min LED life expectancy: 20.000 hours (at full load of LEDs)  
RGBW/CMY colour mixing +CTO

### Virtual colour wheel

68 preset colours  
CTC in range of 2700K-8000K  
Halogen lamp effect at whites 2700K and 3200K  
Rainbow effect with in both directions with variable speed

### Zoom

Linear motorized zoom: 4°-27° (Flower Effect Off)  
4°-23° (Flower Effect On)

### Strobe

Strobe effect with variable speed (0.3 - 20Hz)

**Dimmer**

Smooth dimmer from 0 - 100 %

**Prism**

3-facet rotating prism with continuous rotation in both directions

**Effect**

Flower effect rotating in both directions  
10 Flower effect macros

**Pan/Tilt**

Pan movement range 540° (switchable to 360°)  
Tilt movement range 360°  
Continual pan/tilt rotation  
16 bit movement resolution  
Automatic Pan/Tilt position correction  
Remotely controllable speed of pan/tilt

**Control**

2-row LCD display & 4 buttons  
Readout fixture usage, receiving DMX values, temperatures, etc  
Built-in analyzer for easy fault finding, error messages  
Built-in demo sequences  
Silent fans cooling,  
Stand-alone operation  
3 user editable programs, each up to 40 steps  
Supported protocols: USITT DMX 512, RDM,  
2 DMX modes (27, 21 control channels)

**External Wireless DMX/RDM module (option)**

Compliance with USITT DMX-512 (1986 & 1990) and 512-A  
Full DMX fidelity and frame integrity  
Auto sensing of DMX frame rate and frame size  
<5ms DMX latency  
Operational frequency range of 2402-2480 MHz  
Producer: LumenRadio

**Connection**

DMX data in/out: Locking 5-pin XLR  
Power IN: Neutrik NAC3MPX  
Power OUT: Neutrik NAC3FPX

**Rigging**

Mounting points: pair of 1/4-turn locks  
Mounting horizontally or vertically via one Omega holder

**Temperatures**

Maximum ambient temperature : 45° C  
Maximum housing temperature : 70° C

**Distances**

Min. distance from flammable surfaces: 0.4 m  
Min. distance to lighted object: 0.8 m

**Total heat dissipation**

340 BTU/h (calculated)

## Weight (net)

7.5 kg

## Dimensions (mm)

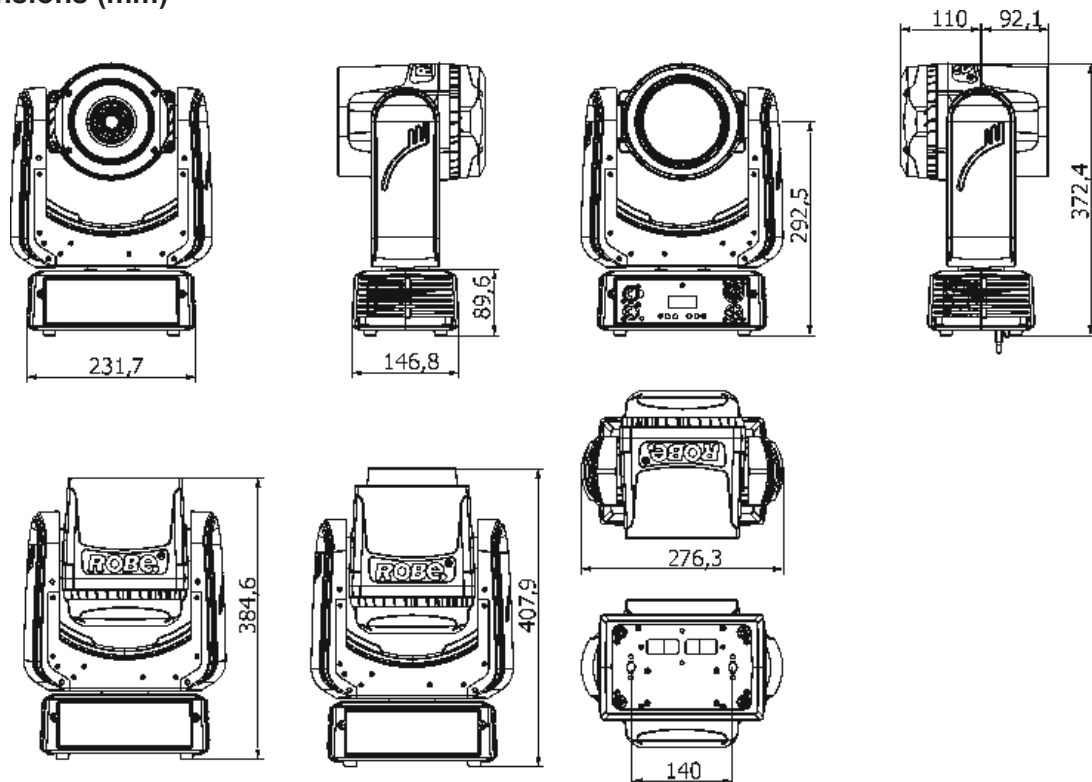

## ROBE Wireless CRMX Dongle for compact ROBIN fixtures

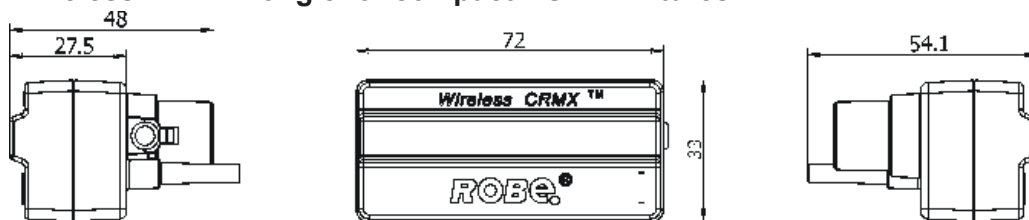

## Accessories

1 x Mounting bracket Omega CL assembled (P/N 99010420)

## Optional accessories

- (P/N 10980127) ROBE Wireless CRMX Dongle for compact ROBIN fixtures
- (P/N 1305 2439) Daisy Chain PowerCon TRUE1 In/Out, EU, 2m, indoor
- (P/N 1305 2440) Daisy Chain PowerCon TRUE1 In/Out, US, 2m, indoor
- (P/N 13052444) Daisy Chain PowerCon TRUE1 In/Out, EU, 5m, indoor
- (P/N 1305 2405) Mains Cable PowerCon In TRUE1/Schuko, 2m, indoor
- (P/N 1305 2406) Mains Cable PowerCon In TRUE1/US, 2m, indoor
- (P/N 1305 2407) Mains Cable PowerCon In TRUE1/open ended, 2m, indoor
- (P/N 13052445) Mains Cable PowerCon In TRUE1/CEE 16A, 2m, indoor
- (P/N 10980033) Omega Adaptor CL-regular 2 pcs (1 pc is already supplied in box as standard)
- (P/N 17030386) Doughty Trigger Clamp
- (P/N 99011963) Safety wire 35 kg



## 10. Maintenance and cleaning

***DANGER !***  
***Disconnect from the mains before starting any  
maintenance work***

A soft lint-free cloth moistened with any good glass cleaning fluid is recommended, under no circumstances should alcohol or solvents be used!

**Never use alcohol or solvents for cleaning the front lens and covers of the fixture**

It is absolutely essential that the fixture is kept clean and that dust, dirt and smoke-fluid residues must not build up on or within the fixture. Otherwise, the fixture's light-output will be significantly reduced. Regular cleaning will not only ensure the maximum light-output, but will also allow the fixture to function reliably throughout its life. A soft lint-free cloth moistened with any good glass cleaning fluid is recommended, under no circumstances should alcohol or solvents be used!

Front lens may require weekly cleaning as smoke-fluid tends to building up residues, reducing the light output very quickly. The cooling fans should be cleaned according to the situation (at least annually). The interior of the head and base should be cleaned at least annually using a vacuum-cleaner.

Periodically clean the air filter placed in the fixture base. Use a vacuum cleaner, compressed air or you can wash it and put back dry.

The guide rods of zoom module should be lubricated monthly (or according to the current situation of movement of zoom module -). Use a suitable lubricant (e.g. oil Aronix /100ml/, P/N 90031114).

More complicated maintenance and service operations are only to be carried out by authorized distributors.

## 10.1 Replacing the fuse

**Before replacing the fuse, unplug mains lead!**

1. Replace the fuse by a fuse of the same type and rating only.

2. Remove the plastic covers of the base (1) by unscrewing two fastening screws (2) on each cover.

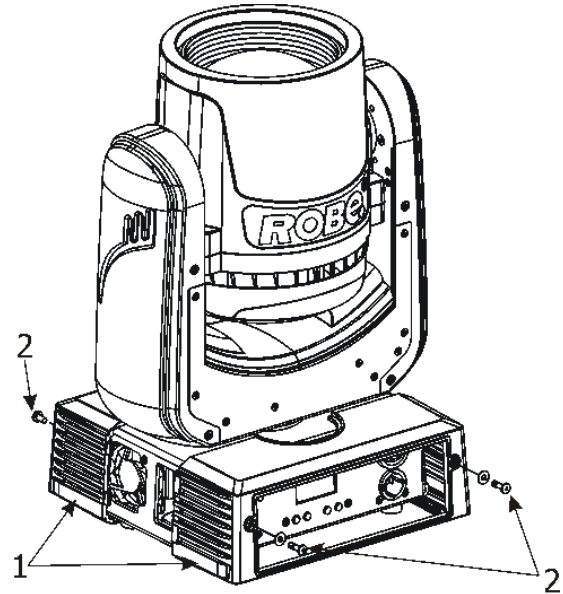

3. Unscrew four screws (3) on the top chassis (4). Lay down the fixture and unscrew four screws (5) on the bottom plate (8) to push out inside module of the base.

4. Unscrew two screws (7) on the bottom plate to remove rear panel of the fixture (6).

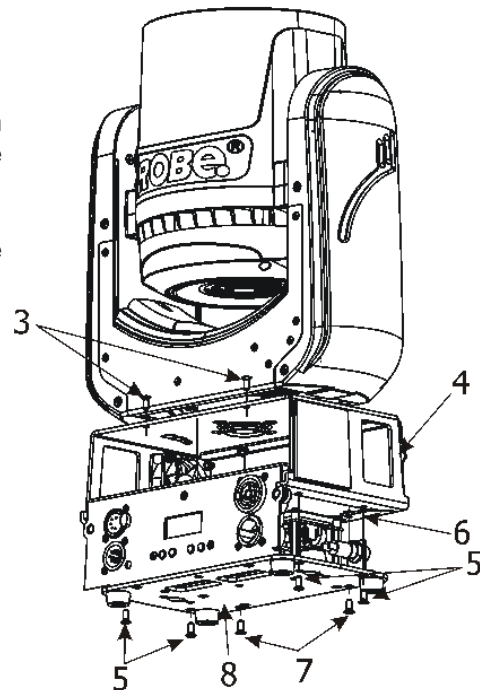

5. Now you have access to the fuse holder (9) in the inside module of the base.

6. Remove the old fuse from the fuse holder.

7. Install the new fuse into the fuse holder.

8. Assemble the base of the fixture.

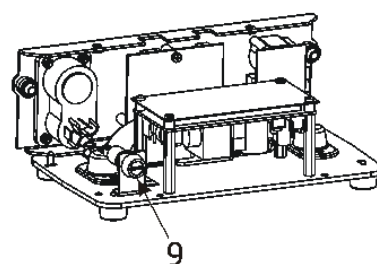

## 10.2 Cleaning of the air filter

**Before cleaning the air filter, unplug mains lead!**

1. Remove the front plastic cover of the base (1) by unscrewing two fastening screws (2) on the cover.

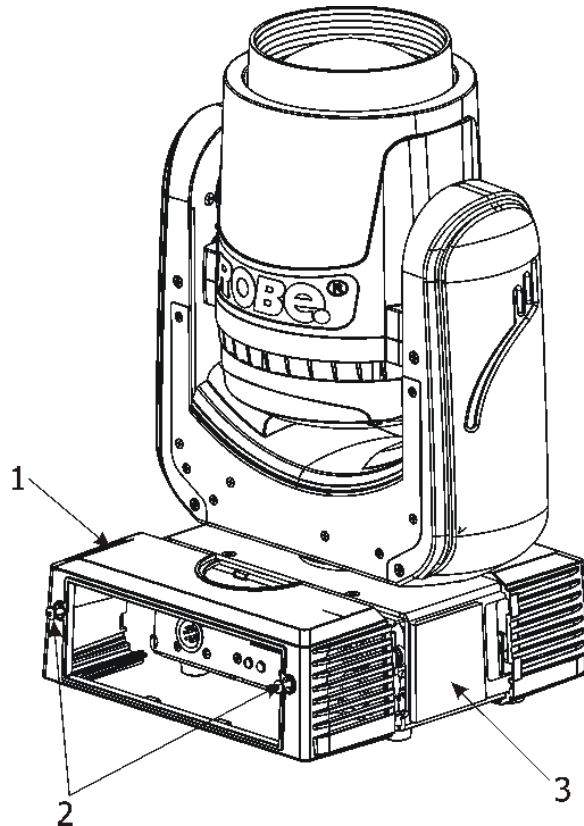

2. Clean the air filter (3) placed in the base. Use a vacuum cleaner, compressed air or you can wash it and put back dry.

After replacing the air filter, reset the elapsed time counter in the menu Information.  
(Info--->Air fil---> R Ti.).

3. Place the base cover back and fasten it by means of two screws (2).

## 10.3 Checking plastic parts of the fixture

The plastic parts of the fixture should be checked for damages and beginning cracks at least every two months. If hint of a crack is found on some plastic part, do not use the fixture until the damaged part will be replaced. Cracks or another damages of the plastic parts can be caused by the fixture transportation or manipulation and also ageing process may influence plastic materials.

This checking is necessary for both fixed installations and preparing fixtures for renting. Any free moving parts inside of the fixture or any cracked plastic not sitting properly in place need to be immediately replaced.

## 10.4 Disposing of the product

To preserve the environment please dispose or recycle this product at the end of its life according to the local regulations and codes.

# 11. Photometric diagrams

## Min. Zoom Flower Effect Off

Total Output: 600 lumens

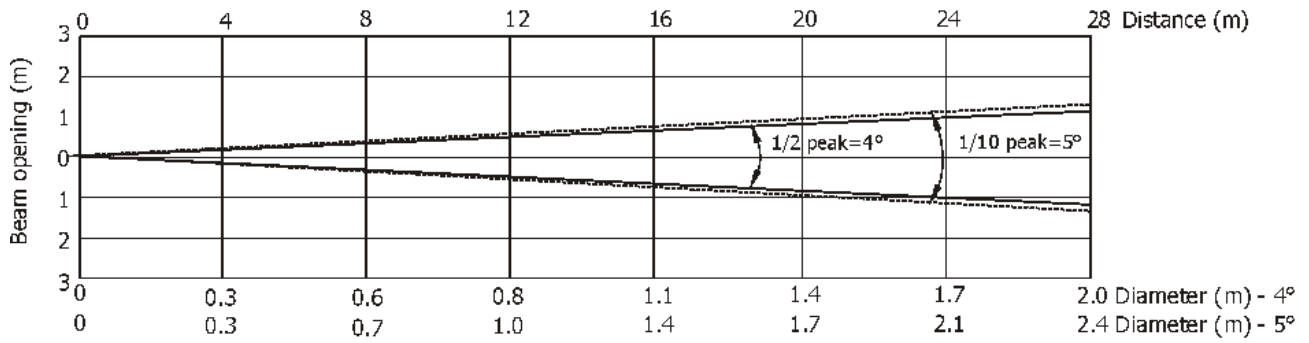

Distance (m)	4	5	8	12	16	20	24	28	Intensity (center) Lux/footcandles
Red	2422/225	1550/144	605/56	270/25	151/14	97/9	67/6	50/5	
Green	5156/479	3300/307	1290/120	573/53	322/30	206/19	143/13	105/10	
Blue	765/71	490/46	191/18	85/8	48/4	31/2.8	21/2	16/1.5	
White	6875/639	4400/409	1718/160	764/71	430/40	275/26	191/18	140/13	
R+G+B+W	14484/1346	9270/861	3621/336	1609/150	905/84	579/54	402/37	296/28	

## Illuminance distribution

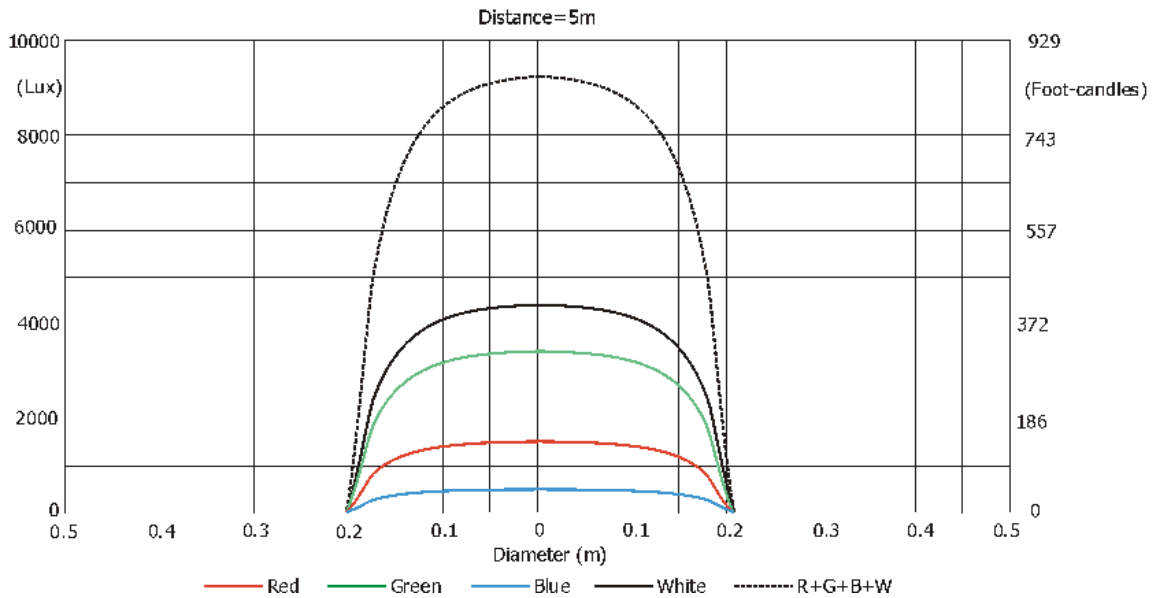

## Max. Zoom Flower Effect Off

Total Output: 920 lumens

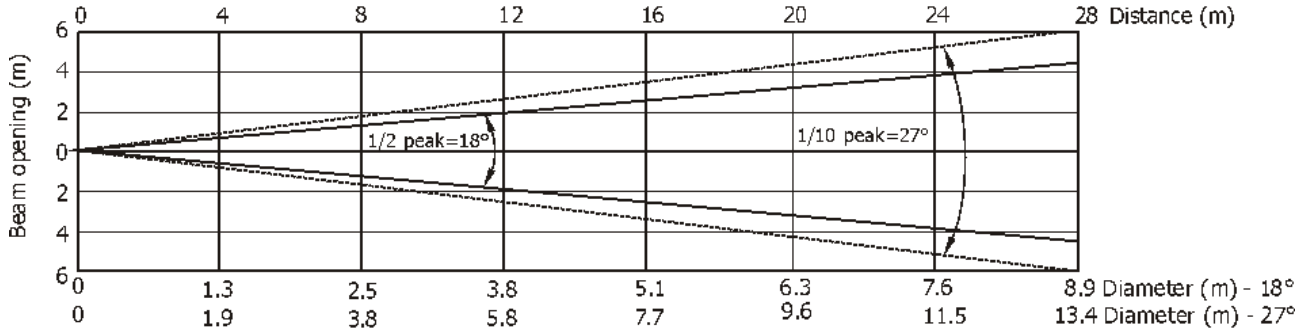

Distance (m)	4	5	8	12	16	20	24	28	
Red	125/12	80/7.4	31/3	14/1.3	8/0.7	5/0.5	4/0.3	2/0.2	Intensity (center) Lux/footcandles
Green	266/25	170/16	66/6.2	30/2.7	17/1.5	10/1	7/0.7	5/0.5	
Blue	40/3.8	26/2.4	10/0.9	5/0.4	3/0.2	2/0.2	1/0.1	0.8/0.1	
White	344/32	220/20	87/8	38/4	22/2	14/1.3	9/0.9	7/0.7	
R+G+B+W	727/68	465/43	180/17	80/8	45/4.2	29/2.7	20/1.9	15/1.4	

### Illuminance distribution

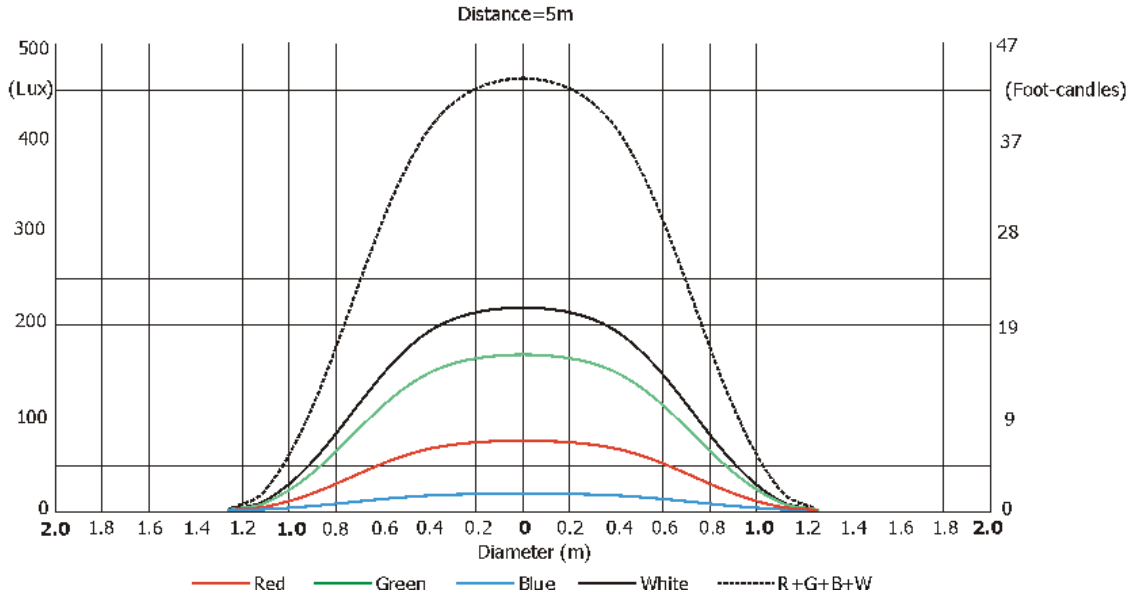

## Min. Zoom Flower Effect On

Total Output: 870 lumens

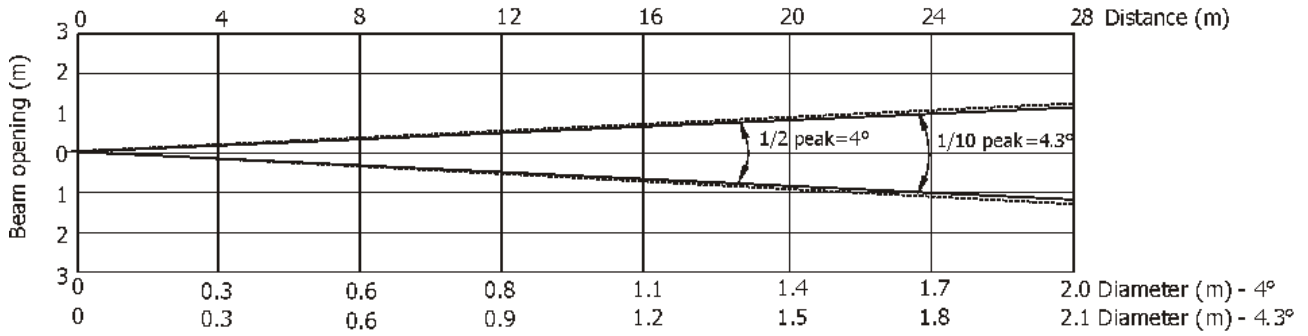

Distance (m)	4	5	8	12	16	20	24	28	Intensity (center) Lux/Footcandles
Red	3250/301	2080/193	813/76	361/34	203/19	130/12	90/8	66/6	
Green	6328/588	4050/376	1582/147	703/65	396/37	253/24	176/16	130/12	
Blue	1078/100	690/64	270/25	120/11	67/6	43/4	30/2.8	22/2	
White	9688/900	6200/576	2422/225	1076/100	605/56	388/36	269/25	198/18	
R+G+B+W	19530/1814	12500/1161	4882/454	2170/202	1220/113	781/73	540/50	398/37	

### Illuminance distribution

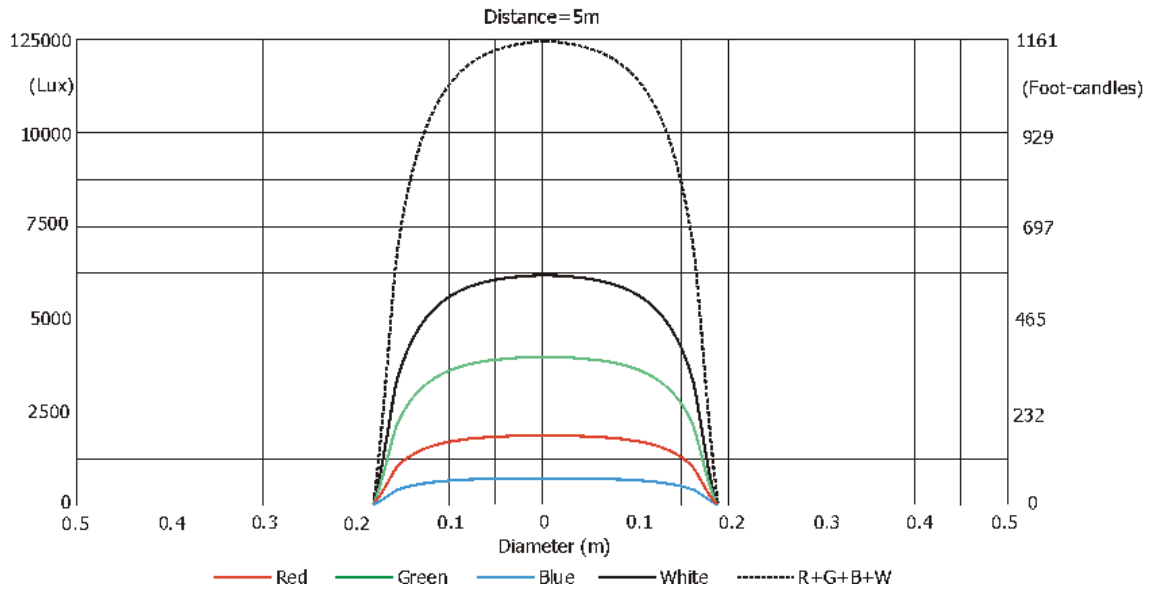

## Max. Zoom Flower Effect On

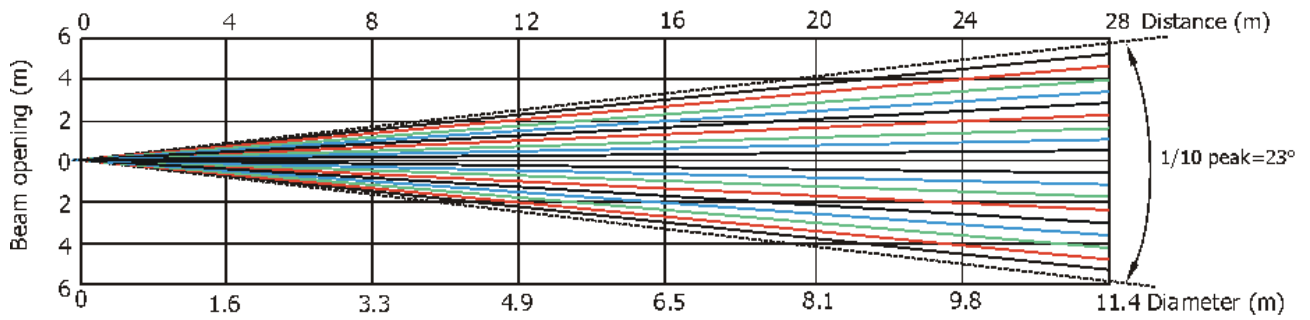

Distance (m)	4	5	8	12	16	20	24	28	
Red	468/44	300/28	117/11	52/5	29/3	19/1.7	13/1.2	10/0.9	Intensity (center) Lux/ Footcandles
Green	1860/173	1190/111	465/43	207/19	116/11	74/7	52/5	38/3.5	
Blue	133/12	85/8	33/3	15/1.4	8/0.8	5/0.5	4/0.3	3/0.3	
White	2250/209	1440/134	563/52	250/23	140/13	90/8	63/6	46/4	

### Image on the screen (just for illustration)

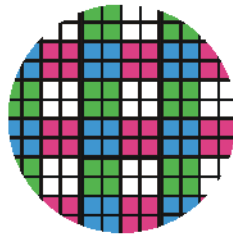

## 12. ChangeLog

This section summarizes changes in the user manual.

Version of the manual	Date of issue	Description of changes
1.1	20/07/2016	Added chapter "Remotely controllable functions"
1.2	10/09/2016	DMX protocol ver. 1.2
1.3	04/04/2017	DMX protocol ver. 1.3 (colours renamed)
1.4	17/01/2018	Optional accessories changed
1.5	30/04/2018	DMX protocol ver. 1.4
1.6	31/07/2019	Check of plastic parts added (chapter Maintenance and cleaning)
1.7	26/02/2020	Detail description of Pan control/Tilt control functions added
1.8	05/11/2020	DMX protocol ver. 1.5 (PWM output frequency of LEDS added)
1.9	08/11/2022	Intensity calibration added



## DMX protocol

Robin Spikie+/Robin Spikie - DMX protocol				
Version: 1.5 Mode 1-Standard 16-bit, Mode 2 -Reduced 8-bit				
Mode/channel		DMX Value	Function	Type of control
1	2			
1	1		<b>Pan (8 bit)</b>	
		0 - 255	Pan movement by 540°/360° (128=default)	proportional
2	2		<b>Pan Fine (16 bit)</b>	
		0 - 255	Fine control of pan movement (0=default)	proportional
3	3		<b>Tilt (8 bit)</b>	
		0 - 255	Tilt movement by 360° (128=default)	proportional
4	4		<b>Tilt fine (16 bit)</b>	
		0 - 255	Fine control of tilt movement (0=default)	proportional
5	5		<b>Pan control*</b>	
		0	Pan range 540°, shortcut Off (0=default)	step
		1	Pan range 360°, shortcut On	step
		2-127	No function (Pan range 540°, shortcut Off)	
		128-189	Continuous rotation fast -> slow , Forwards	proportional
		190-193	Stop rotation	step
		194-255	Continuous rotation slow -> fast , Backwards	proportional
6	6		<b>Tilt control*</b>	
		0	Tilt range 360°, Shortcut Off (0=default)	step
		1	Tilt range 360°, Shortcut On	step
		2-127	No function (Tilt range 360°, Shortcut Off)	
		128-189	Continuous rotation fast -> slow , Forwards	proportional
		190-193	Stop rotation	step
		194-255	Continuous rotation slow -> fast , Backwards	proportional
7	7		<b>Pan/Tilt speed , Pan/Tilt time</b>	
		0	Max. speed-Standard Mode (0=default)	step
			<b>P./T. speed-set Speed Mode in menu: Pan/Tilt Mode</b>	
		1 - 255	Speed from max. to min.	proportional
			<b>P./T. time - set Time Mode in menu: Pan/Tilt Mode</b>	
		1 - 255	Time from 0.1 s to 25.5 sec.	proportional
8	8		<b>Power/Special functions</b>	
		0 -19	Reserved (0=default) <i>To activate following functions, stop in DMX value for at least 3 s and shutter must be closed at least 3 sec. („Shutter,Strobe“ channel 25/20 must be at range: 0-31 DMX). Corresponding menu items are temporarily overridden.</i>	
		20-24	Display ON	step
		25-29	Display OFF	step
		30-34	RGBW colour mixing mode	step
		35-39	CMY colour mixing mode	step
		40-44	Pan/Tilt speed mode	step
		45 - 49	Pan/Tilt time mode	step
		50 -54	Blackout while pan/tilt moving	step
		55 -59	Disabled blackout while pan/tilt moving	step
		60 - 64	Dimmer curve - square law	step
		65 - 69	Dimmer curve - linear	step
		70 - 74	Fans mode: Auto	step
		75 - 79	Fans mode: High	step
		80-84	White point 8000K ON	step

DMX protocol

Mode/channel		DMX Value	Function	Type of control
1	2			
		85-89	White point 8000K OFF	step
		90 -129	Reserved	
			<i>To activate following functions, stop in DMX value for at least 3 seconds.</i>	
		130 - 139	Fixture reset (except pan/tilt)	
		140 - 149	Pan/Tilt reset	step
		150 - 159	Zoom reset	step
		160 - 169	Flower effect/prism reset	step
			<i>Tungsten effect simulation for whites 2700K and 3200K</i>	
		170-171	Tungsten effect simulation (750W) On	step
		172-173	Tungsten effect simulation (1000W) On	step
		174-175	Tungsten effect simulation (1200W) On	step
		176-177	Tungsten effect simulation (2000W) On	step
		178-179	Tungsten effect simulation (2500W) On	step
		180-181	Tungsten effect simulation Off	step
		182-184	Reserved	
		185	PWM output frequency of LEDS: Standard (300Hz)***	step
		186	PWM output frequency of LEDS: High (600Hz)***	step
			*** You can adjust selected frequency in 6 steps Up or Down around selected frequency - see table below . Default value of PWM frequency set in the fixture is Standard.	
		187	LED Frequency (step -6)	step
		188	LED Frequency (step -5)	step
		189	LED Frequency (step -4)	step
		190	LED Frequency (step -3)	step
		191	LED Frequency (step -2)	step
		192	LED Frequency (step -1)	step
		193	LED Frequency (Standard or High)	step
		194	LED Frequency (step +1)	step
		195	LED Frequency (step +2)	step
		196	LED Frequency (step +3)	step
		197	LED Frequency (step +4)	step
		198	LED Frequency (step +5)	step
		199	LED Frequency (step +6)	step
		200 - 209	Total fixture reset	step
		210 - 255	Reserved	
<b>9</b>	<b>9</b>		<b>Virtual colour wheel</b>	
		0	No function (0=default)	step
		1-2	Filter 4 (Medium Bastard Amber)	step
		3-4	Filter 25 (Sunset Red)	step
		5-6	Filter 19 (Fire)	step
		7-8	Filter 26 (Bright Red)	step
		9-10	Filter 58 (Lavender)	step
		11-12	Filter 68 (Sky Blue)	step
		13-14	Filter 36 (Medium Pink)	step
		15-16	Filter 89 (Moss Green)	step
		17-18	Filter 88 (Lime Green)	step
		19-20	Filter 90 (Dark Yellow Green)	step
		21-22	Filter 49 (Medium Purple)	step
		23-24	Filter 52 (Light Lavender)	step

DMX protocol

Mode/channel		DMX Value	Function	Type of control
1	2			
		25-26	Filter 102 (Light Amber)	step
		27-28	Filter 103 (Straw)	step
		29-30	Filter 140 (Summer Blue)	step
		31-32	Filter 124 (Dark Green)	step
		33-34	Filter 106 (Primary Red)	step
		35-36	Filter 111 (Dark Pink)	step
		37-38	Filter 115 (Peacock Blue)	step
		39-40	Filter 126 (Mauve)	step
		41-42	Filter 117 (Steel Blue)	step
		43-44	Filter 118 (Light Blue)	step
		45-46	Filter 122 (Fern Green)	step
		47-48	Filter 182 (Light Red)	step
		49-50	Filter 121 (Filter Green)	step
		51-52	Filter 128 (Bright Pink)	step
		53-54	Filter 131 (Marine Blue)	step
		55-56	Filter 132 (Medium Blue)	step
		57-58	Filter 134 (Golden Amber)	step
		59-60	Filter 135 (Deep Golden Amber)	step
		61-62	Filter 136 (Pale Lavender)	step
		63-64	Filter 137 (Special Lavender)	step
		65-66	Filter 138 (Pale Green)	step
		67-68	Filter 798 (Chrysalis Pink)	step
		69-70	Filter 141 (Bright Blue)	step
		71-72	Filter 147 (Apricot)	step
		73-74	Filter 148 (Bright Rose)	step
		75-76	Filter 152 (Pale Gold)	step
		77-78	Filter 154 (Pale Rose)	step
		79-80	Filter 157 (Pink)	step
		81-82	Filter 143 (Pale Navy Blue)	step
		83-84	Filter 162 (Bastard Amber)	step
		85-86	Filter 164 (Flame Red)	step
		87-88	Filter 165 (Daylight Blue)	step
		89-90	Filter 169 (Lilac Tint)	step
		91-92	Filter 170 (Deep Lavender)	step
		93-94	Filter 172 (Lagoon Blue)	step
		95-96	Filter 194 (Surprise Pink)	step
		97-98	Filter 180 (Dark Lavender)	step
		99-100	Filter 181 (Congo Blue)	step
		101-102	Filter 197 (Alice Blue)	step
		103-104	Filter 201 (Full C.T. Blue)	step
		105-106	Filter 202 (Half C.T. Blue)	step
		107-108	Filter 203 (Quarter C.T. Blue)	step
		109-110	Filter 204 (Full C.T. Orange)	step
		111-112	Filter 219 (Fluorescent Green)	step
		113-114	Filter 206 (Quarter C.T. Orange)	step
		115-116	Filter 247 (Filter Minus Green)	step
		117-118	Filter 248 (Half Minus Green)	step
		119-120	Filter 281 (Three Quarter C.T. Blue)	step
		121-122	Filter 285 (Three Quarter C.T. Orange)	step

DMX protocol

Mode/channel		DMX Value	Function	Type of control
1	2			
		123-124	Filter 352 (Glacier Blue)	step
		125-126	Filter 353 (Lighter Blue)	step
		127-128	Filter 507 (Madge)	step
		129-130	Filter 778 (Millennium Gold)	step
		131-132	Filter 793 (Vanity Fair)	step
		133-235	Reserved	
		236-245	Rainbow effect (with fade time) from slow-> fast	proportional
		246-255	Rainbow effect (without fade time) from slow-> fast	proportional
<b>10</b>	<b>10</b>		<b>Red/Cyan (8 bit)**</b>	
		0 - 255	Colour saturation control - coarse 0-100% (255=default)	proportional
<b>11</b>	*		<b>Red/Cyan (16bit)**</b>	
		0 - 255	Colour saturation control - fine (255=default)	proportional
<b>12</b>	<b>11</b>		<b>Green/Magenta (8 bit) **</b>	
		0 - 255	Colour saturation control - coarse 0-100% (255=default)	proportional
<b>13</b>	*		<b>Green/Magenta (16bit) **</b>	
		0 - 255	Colour saturation control - fine (255=default)	proportional
<b>14</b>	<b>12</b>		<b>Blue/Yellow (8 bit) **</b>	
		0 - 255	Colour saturation control - coarse 0-100% (255=default)	proportional
<b>15</b>	*		<b>Blue/ Yellow (16bit) **</b>	
		0 - 255	Colour saturation control - fine (255=default)	proportional
<b>16</b>	<b>13</b>		<b>White (8 bit)</b>	
			<i>If RGBW mode is selected:</i>	
		0-255	Colour saturation control - coarse 0-100% (255=default)	proportional
			<i>If CMY mode is selected:</i>	
		0 - 255	No function	
<b>17</b>	*		<b>White (16 bit)</b>	
		0 - 255	Colour saturation control - fine (255=default)	proportional
<b>18</b>	<b>14</b>		<b>CTC</b>	
			<i>If function "White Point 8000K" is ON</i>	
		0-255	Col. temperature correction from 8000K to 2700K -for whites only (0=8000K, 64=5600K, 128=4200K, 192=3200K, 255=2700K) To get colour temperatures stated above, RGBW channels have to be set at the same value e.g. 255DMX (0=default) (To activate Tungsten effect at 2700K and 3200K , set DMX value at "Power/Special functions" channel)	proportional
			<i>If function "White Point 8000K" is OFF</i>	
		0-255	Colour temperature correction for from cool white to 2700K	proportional
<b>19</b>	<b>15</b>		<b>Colour Mix control</b>	
			<i>Defines relation between colour channels</i>	
			"Virtual" = Virtual Colours (Virtual Colour Wheel)	
			"Colour mix" = Colour channels (RGBW/CMY)	
		0-9	Virtual colors ("Virtual" has priority)	step
		10-19	Maximum mode (highest values have priority)	step
		20-29	Minimum mode (lowest values have priority)	step
		30-39	Multiply mode (multiply Virtual and Colour Mix)	step
		40-49	Addition mode (Virtual + Colour mix) (45=default)	step
		50-59	Subtraction mode (Virtual – Colour mix)	step
		60-69	Inverted Subtraction mode (Colour mix-Virtual)	step
		70-128	Reserved	
		129	Virtual colors (virtual has priority)	step

DMX protocol

Mode/channel		DMX Value	Function	Type of control
1	2			
		130-254	Crossfade (crossfade between Virtual and Colour mix)	proportional
		255	Colour channels ("Colour mix" has priority)	step
<b>20</b>	<b>16</b>		<b>Rotating Prism</b>	
		0	Open position-without prism (0=default)	step
		1 - 127	Prism inserted, forwards rotation from fast to slow	proportional
		128	No rotation-prism inserted	step
		129-255	Prism inserted, backwards rotation from slow to fast	proportional
<b>21</b>	<b>17</b>		<b>Flower Effect</b>	
		0	Open position-without Flower Effect (0=default)	step
		1 - 127	Flower effect on, forwards rotation from fast to slow	proportional
		128	Flower effect on, no rotation	step
		129-255	Flower effect on, backwards rotation from slow to fast	proportional
<b>22</b>	<b>18</b>		<b>Flower Effect &amp; Rotating prism macros</b>	
		0	Open position - without macros (0=default) <i>In range of 1-20 DMX, channels Rotating prism and Flower Effect are blocked</i>	step
		1-2	Macro 1	step
		3-4	Macro 2	step
		5-6	Macro 3	step
		7-8	Macro 4	step
		9-10	Macro 5	step
		11-12	Macro 6	step
		13-14	Macro 7	step
		15-16	Macro 8	step
		17-18	Macro 9	step
		19-20	Macro 10	step
		21-255	Reserved	
<b>23</b>	<b>19</b>		<b>Zoom</b>	
		0-255	Zoom from max. to min.beam angle (128=default)	proportional
<b>24</b>	<b>*</b>		<b>Zoom - fine</b>	
		0-255	Fine zooming (0=default)	proportional
<b>25</b>	<b>20</b>		<b>Shutter/ strobe</b>	
		0 - 31	Shutter closed	step
		32 - 63	Shutter open (32=default)	step
		64 - 95	Strobe-effect from slow to fast	proportional
		96 - 127	Shutter open	step
		128 - 143	Opening pulse in sequences from slow to fast	proportional
		144 - 159	Closing pulse in sequences from fast to slow	proportional
		160 - 191	Shutter open	step
		192 - 223	Random strobe-effect from slow to fast	proportional
		224 - 255	Shutter open	step
<b>26</b>	<b>21</b>		<b>Dimmer intensity (8 bit)</b>	
		0 - 255	Dimmer intensity from 0% to 100% (0=default)	proportional
<b>27</b>	<b>*</b>		<b>Dimmer intensity - fine (16 bit)</b>	
		0 - 255	Fine dimming (0=default)	proportional

\* Max. Speed of continual Tilt rotation depends on max. speed of continual Pan rotation and vice versa

E.g. Max. Tilt speed is reduced with increasing Pan speed, and vice versa, Max. Pan speed is reduced with increasing Tilt speed

\*\*Select RGB or CMY mixing mode on channel "Power/Special functions".

Copyright © 2016-2022 Robe Lighting s.r.o. - All rights reserved

All Specifications subject to change without notice

<b>Robin Spikie+/Robin Spikie - colours on Virtual Colour Wheel</b>				
<b>Colour name</b>	<b>Red (DMX)</b>	<b>Green (DMX)</b>	<b>Blue (DMX)</b>	<b>White (DMX)</b>
Filter 4 (Medium Bastard Amber)	255	104	0	39
Filter 25 (Sunset Red)	255	50	0	3
Filter 19 (Fire)	255	33	0	0
Filter 26 (Bright Red)	255	0	0	0
Filter 58 (Lavender)	117	0	39	110
Filter 68 (Sky Blue)	42	255	83	6
Filter 36 (Medium Pink)	255	74	8	24
Filter 89 (Moss Green)	97	255	0	3
Filter 88 (Lime Green)	255	226	0	0
Filter 90 (Dark Yellow Green)	16	255	1	0
Filter 49 (Medium Purple)	255	0	27	0
Filter 52 (Light Lavender)	254	86	9	110
Filter 102 (Light Amber)	255	140	0	0
Filter 103 (Straw)	255	137	0	29
Filter 140 (Summer Blue)	0	199	0	218
Filter 124 (Dark Green)	28	255	0	14
Filter 106 (Primary Red)	255	12	0	0
Filter 111 (Dark Pink)	255	67	11	18
Filter 115 (Peacock Blue)	13	255	24	41
Filter 126 (Mauve)	255	0	32	0
Filter 117 (Steel Blue)	217	255	0	161
Filter 118 (Light Blue)	0	255	42	34
Filter 122 (Fern Green)	115	255	0	7
Filter 182 (Light Red)	255	16	2	0
Filter 121 (Filter Green)	204	255	0	0
Filter 128 (Bright Pink)	255	0	13	32
Filter 131 (Marine Blue)	83	245	23	30
Filter 132 (Medium Blue)	0	255	89	0
Filter 134 (Golden Amber)	255	89	0	3
Filter 135 (Deep Golden Amber)	255	43	0	0
Filter 136 (Pale Lavender)	171	96	13	36
Filter 137 (Special Lavender)	145	58	21	158
Filter 138 (Pale Green)	255	208	0	25
Filter 798 (Chrysalis Pink)	57	0	32	23
Filter 141 (Bright Blue)	0	255	55	0
Filter 147 (Apricot)	255	99	0	12
Filter 148 (Bright Rose)	255	3	0	27
Filter 152 (Pale Gold)	244	109	0	30
Filter 154 (Pale Rose)	236	104	0	35
Filter 157 (Pink)	255	56	5	21
Filter 143 (Pale Navy Blue)	0	255	52	156
Filter 162 (Bastard Amber)	223	111	0	35
Filter 164 (Flame Red)	255	30	0	0
Filter 165 (Daylight Blue)	35	255	59	81
Filter 169 (Lilac Tint)	255	123	0	72
Filter 170 (Deep Lavender)	255	123	25	9
Filter 172 (Lagoon Blue)	0	255	40	0

<b>Colour name</b>	<b>Red (DMX)</b>	<b>Green (DMX)</b>	<b>Blue (DMX)</b>	<b>White (DMX)</b>
Filter 194 (Surprise Pink)	135	0	0	208
Filter 180 (Dark Lavender)	180	72	94	55
Filter 181 (Congo Blue)	57	0	255	0
Filter 197 (Alice Blue)	134	228	75	0
Filter 201 (Full C.T. Blue)	230	228	35	51
Filter 202 (Half C.T. Blue)	255	199	20	38
Filter 203 (Quarter C.T. Blue)	255	163	0	80
Filter 204 (Full C.T. Orange)	223	104	0	9
Filter 219 (Fluorescent Green)	139	255	0	132
Filter 206 (Quarter C.T. Orange)	255	140	0	33
Filter 247 (Filter Minus Green)	255	81	0	74
Filter 248 (Half Minus Green)	255	119	0	59
Filter 281 (Three Quarter C.T. Blue)	255	216	20	143
Filter 285 (Three Quarter C.T. Orange)	255	122	0	15
Filter 352 (Glacier Blue)	0	216	44	92
Filter 353 (Lighter Blue)	0	120	12	82
Filter 507 (Madge)	255	31	0	0
Filter 778 (Millennium Gold)	255	58	0	0
Filter 793 (Vanity Fair)	255	0	12	15